

**Universität Bielefeld/IMW**

**Working Papers  
Institute of Mathematical Economics**

**Arbeiten aus dem  
Institut für Mathematische Wirtschaftsforschung**

Nr.155

**Equilibria in Markets with Incomplete  
Information on Qualities**

**Hans-Martin Wallmeier  
March 1987**



H. G. Bergenthal

**Institut für Mathematische Wirtschaftsforschung  
an der  
Universität Bielefeld  
Adresse / Address:  
Universitätsstraße  
4800 Bielefeld 1  
Bundesrepublik Deutschland  
Federal Republic of Germany**

## 1. Introduction

A large portion of economic activities takes place under various kinds of lack of information on the relevant factors for the final benefit. Consequently the investigation of models describing specific types of uncertainty became more and more important during the last four decades. Uncertainty of the economic subjects may arise exogeneously or endogeneously. The first case emerges when the participants of the market behave randomly and not mutually observable, e.g. as a consequence of simultaneous moves. The second reason for uncertainty is given by randomly occurring events. Here it is assumed that the underlying random-mechanism is not subject to the strategic considerations of the participants. In their survey article HIRSCHLEIFER and RILEY [79] used the suggestive terms "market uncertainty" and "event unvertainty" to discriminate both cases.

Due to their complexity models involving uncertainty are usually tackled as partial models. The overwhelming part of the literature within this area is related to information structures which are exogeneously given. Thus strategic considerations of the players are restricted on the actions to be taken and not to the information which may be processed. The information structure, describing the amount and form of information which can be acquired by the subjets, consequently has to be viewed to be a - decisive - parameter of any model.

Quite recently a lot of rigorous analysis on equilibria in oligopolistic markets with imperfectly informed buyers has been performed. The underlying information structure provides signals for the buyers on prices which are charged by the sellers.

The basic structure is given as follows. A finite number of suppliers of a homogeneous good is given. They compete by independently fixing prices. The demand sector is introduced by assuming the existence of a "large" number of consumers. They are supposed to satisfy the expected utility hypothesis, that is, they maximize their expected payoff in accordance with the standard theory of decision under uncertainty. Being faced with some price

when entering a specific store they charge a quantity according to their demand function. Uncertainty comes into the model from assuming the prices to be not publicly known. Instead some signalling mechanism exogeneously given provides partial information on the prices charged by different suppliers. The outcome of the signalling mechanism is supposed to be randomly affected by the prices charged by the suppliers.

In most models consumers are assumed to be price-takers. Therefore bargaining on prices and/or leaving a store without buying is forbidden by the rules. Usually this rule is motivated by very large search costs, although there exist models (e.g. H. BESTER [83]) allowing for bargaining. Leaving the store is contained as an "outside option", though it is not realized in equilibrium.

Assuming the consumers' decision functions to be fixed they only serve to define payoffs to the suppliers in the standard oligopolistic market model with imperfectly informed buyers. Thus it is only the behavior of the suppliers which has to be characterized endogeneously. We observe the consumers' behavior to define a non-cooperative game among the suppliers. The strategies herein are the prices which are charged by the players/suppliers. Game theory now becomes applicable and provides an answer on the benefit for the players, or, as a theory of rational recommendation, suggests a specific form of behavior to the players. The solution/recommendation, which is provided, is the well-known Nash-equilibrium. Its existence and form is the main point under consideration in those models. Besides the existence the most important point on equilibria is its variation depending on the information structure. It should be kept in mind that a comparative static approach to the development of equilibria is not in general available. Difficulties usually crop up when the existence is ensured by means of a (non-constructive) fixed-point theorem.

## II. The Model

In contrast to the above approach the general structure comprises two markets with intermediaires (traders) acting on both of them. As far as the game to be defined is concerned, the traders take over the role of suppliers in the former model.

Our model will be concerned with Bertrand-Competition among intermediaires. They are one hand buyers on an oligopolistic market for a good which exists in different, not directly observable qualities. However, by use of some mechanism some estimation can be given by the intermediaires. The intermediaires publicly announce prices for all qualities of the good. The price corresponding to a certain quality is payed when this specific quality is ascertained. The non constant price-vectors announced arise endogeneously as the "intermediaires" contribution to the equilibrium. On the second oligopolistic market they act as sellers of a homogeneous good. By appropriate assumption (perfect Bertrand-Competition) the price per unit may be found to be constant. Thus it is the difference between the constant and the expected payoff resulting from the announced price-vector which determines the revenues for the intermediaires.

By an example we shall elucidate the model.

### Example

Suppose a used car is going to be sold. By experience the seller has some idea on its quality. This experience may be characterized as a probability distribution  $\omega$  on a finite set  $\mathcal{X}$  of distinct qualities. The cars are assumed only to be sold to one member of a finite set  $\mathcal{N}$  of traders. Each trader is characterized by some technical System  $W^n$  for estimating the quality of the offered car. As any technical system the test-mechanism is subject to misadjustments, it may therefore be assumed to be describable as a stochastic matrix  $W^n | \mathcal{X} \Rightarrow \mathcal{Y}$ , where  $\mathcal{Y}$  denotes the finite set of possible estimates for the quality. The traders offer a specific amount  $p(y)$ , depending on the quality  $y$  as judged by the system. Some vector  $p^n$  of relative prices ( $p^n(y) \geq 0$ ,  $\sum_y p^n(y) = 1$ ) is specified by the traders  $n \in \mathcal{N}$

and will be assumed to be perfectly known to the seller.

Of course the above mentioned car is not the only one on the market, in fact the set of sellers shall basically be identified with the unit interval. (We shall use  $\omega$  for both, the seller  $\omega \in [0,1]$  and his characteristic, the probability distribution on the set of qualities,  $\omega \in \Delta(x)$ .)

We further assume to be given a probability distribution  $\mu$  on  $\Delta(x)$ , the distribution of characteristics.

The traders may buy any number of used cars. Re-selling them they receive a fixed amount  $K \in \mathbb{R}$ .

We assume the parameters  $W^n$  and  $\mu$  to be common knowledge. Also for consistency reasons we assume each seller to be perfectly aware of his type. Having provided the parameters of the model we have now to specify the incentives for the sellers and traders.

Conform to the expected utility hypothesis the sellers are supposed to maximize their expected payoff. Thus, knowing his type, the seller offers his car to one of the traders maximizing

$$\langle \omega * W^m, p^m \rangle = \sum_x \omega(x) \sum_y W^m(y|x) \cdot p^m(y), \quad m \in N$$

his expected payoff. Introducing for each type  $\omega$  and prices  $(p^m)_{m \in N}$  a random variable  $f_\omega((p^m))$  selecting one of the maximizers with equal probability, the payoff for trader  $n \in N$  is given by

$$u^n((p^m)) = \int_{\Omega} 1_{\{n\}}(f_\omega((p^m))) [K - \langle \omega * W^n, p^n \rangle] \mu(d\omega).$$

Regarding price-vectors  $p^m$ ,  $m \in N$  to denote strategic abilities of the traders, a non-cooperative game is defined.

Let us now provide some comments on the example.

### 2.1 Remark

- (i) The assumption of commonly known price-vectors  $p^n$  is a standard assumption in this field. In our second-hand car example it may be supported by the existence of consumer services provided by magazines like the "ADAC-Motorwelt" or by the "Schwacke-Liste". The latter service, originally meant for traders is by now also available to privates.
  
- (ii) Somewhat more difficult to motivate is the assumption on known mechanisms  $W^n$ . However, at least by experience and communication sellers get to know customs of traders. Some of them mainly judge by appearance, some prefer to perform a test on the road and others investigate a lot of technical details very thoroughly.

### 2.2 Remark

The number  $K$  is assumed to be a reselling price for used cars. Implicitly contained in such an assumption is the existence of a market with Bertrand-Competition on a homogeneous good. This condition is more or less roughly met for used cars of some specified type and age via the "Schwacke-Liste" too. A further support to this assumption is provided by recent developments. Frequently traders issue a guarantee for main components of used cars. This type of behavior is supported by performances of insurances such as "Allianz-Versicherung" and "Gerling-Konzern" which take over the risk for the traders.

### 2.3 Remark

The above payoff-function for traders and sellers implicitly generate the assumption that the outcome of the test mechanism is not only observable by the trader, but also by the seller. Indeed, assuming the contrary allows the trader for cheating by pretending the lowest quality to be found. However, in our example the claims of traders are verifiable by the sellers to a large extend.

#### 2.4 Remark

Despite of being a common assumption in the theory of markets with imperfect information we shall provide a few words on the non existence of bargaining and exclusion of using outside options (multiple tests). Admittedly the assumption of having a test on quality only with one trader does not fit the second-hand car example exceedingly well. In fact, the (feasible) juridical mode of procedure of signing a contract with the trader on accepting the price corresponding to the quality which will be estimated, is never formally observed (with privates). However, the tacit agreement on this procedure is likely to be found frequently. Instead, in general some bargaining takes place on the quality (in fact: on the price) of the tested second-hand car. This bargaining may be introduced using a two stage model related to a model suggested by H. BESTER [86]. Within this model leaving a store without signing the contract is allowable - but it is not observed in equilibrium. Leaving without an agreement on sale does only serve as an outside option for the seller. This option is strong enough to increase the offered price to an acceptable height as early as in the first store which is visited. A comparable two stages model could be introduced here too.

Another way of enforcing endogeneously an agreement already with the first trader is provided by introducing search costs. This approach is immediately in the spirit of our model. The costs for performing a test have to be sufficiently high and will only be paid if an agreement does not come to pass. This mode of procedure is common usage when costs for tests are comparably high, e.g. in case of suggestions for furnishing homes, made by furniture dealers.

For convenience, let us shortly summarize the model:

There are two types of agents, suppliers and traders. The former ones own one unit of a good, each. The goods are characterized by their - not directly observable - quality.

The uncountable set of sellers is supposed to be a compact subset  $\Omega$  of the real axis. On  $\Omega$  and its Borel-subsets a measurable transformation

$$T : \Omega \rightarrow \Delta(\mathcal{X})$$

is given<sup>0</sup>, adjusting to each seller the quality distribution of the good that he owns. The Lebesgue measure  $\lambda$  on  $\Omega$  and  $T$  induce a measure  $\mu$  on  $\Delta(\mathcal{X})$ . We assume  $\mu = T \cdot \lambda$  to be atomless. For notational convenience we shall identify  $\omega$  and  $T(\omega)$  hereafter since it is only the distribution on qualities, that matters.

Each of the finite number of traders is characterized by his information structure<sup>1</sup>

$$W^n \mid \mathcal{X} \Rightarrow \mathcal{Y}, \quad n \in N.$$

The traders strategically publicly announce price vectors  $p^n \in \Delta(\mathcal{Y})$ , each and commit themselves on paying  $p^n(y)$  whenever the quality of a good offered by some client is ascertained to be  $y$ .

Each seller offers his good to the trader who promises the highest expected payoff. Given prices  $p^m$ ,  $m \in N$  the payoff for trader  $n$  is given by

$$u^n((p^m)) = \int_{\Omega} 1_{\{f_{\omega}((p^m)) \in W^n, p^n\}} [K - \langle \omega * W^n, p^n \rangle] \mu(d\omega).$$

The random variable  $f_{\omega}((p^m))$  with values in the traders' set express the attitude of supplier  $\omega \in \Omega$  to the traders. It is assumed that  $f_{\omega}((p^m))$  is uniformly distributed on the set of traders promising the maximum expected payoff.

---

<sup>0</sup>  $\Delta(\mathcal{X})$  denotes the set of all probability distribution on  $\mathcal{X}$ .

<sup>1</sup> This terminology is suggested by T.MARSCHAK and R.RADNER [72] and also used by M.NERMUTH [82] for a stochastic transformation of unobservable trivial states into observable, distorted signals.



### III. An Existence Theorem on $\epsilon$ -Equilibria

Within this section we shall derive the existence of  $\epsilon$ -equilibria of the Bertrand-Competition game, for which the payoff-functions and sets of strategies of the players (traders) were given previously. The appropriate restrictions will be made in the course of this section and summarized in the presuppositions of the main theorem.

It may be noticed that the standard game-theoretic assumption for the existence of an equilibrium, the concavity of the payoff function, is not satisfied. A different analytically much simpler approach is used which moreover has the advantage that the  $\epsilon$ -equilibria are constructively obtained.

We shall first find a considerably simpler representation for the payoff-functions.

#### 3.1 Lemma

The set of types  $\omega \in \Delta(x)$  for which trader  $n$  promises the maximum expected payoff, is a convex polyhedron.

#### Proof

For any  $W$  and  $p$  the function

$$\langle \cdot * W, \bar{p} \rangle : \Delta(x) \rightarrow \mathbb{R}$$

is affin linear. The claim follows immediately. #

Within this exposition we shall confine ourselves to the two-qualities case ( $|x| = |y| = 2$ ). In that case the information structure is given by a stochastic matrix

$$W = \begin{pmatrix} w_1 & 1 - w_1 \\ w_2 & 1 - w_2 \end{pmatrix}$$

Let us suppose the signals to be closely related to the qualities. Then the

### 3.2 Regularity Condition

$$w_1 > \frac{1}{2} > w_2$$

becomes most natural.<sup>2</sup>

Price-vectors  $\bar{p}$  in the two-qualities case are defined by their first component, which will be denoted as  $p$ . We shall use both notations exchangeably for the strategy of player 1. Moreover we shall use  $\omega$  for the first component of  $\bar{\omega} \in \Delta(X)$ .

### 3.3 Lemma

Let  $W$  satisfy the regularity condition.

(i) For  $p \neq \frac{1}{2}$  the equality

$$\langle \bar{\omega} * W, \bar{p} \rangle = \frac{1}{2}$$

has exactly one solution in the variables  $\bar{\omega} \in \Delta(X)$ .

(ii) The solution is independent of  $p$ .

### Proof

$$\begin{aligned}
& \langle \bar{\omega} * W, \bar{p} \rangle \\
&= \omega \cdot (w_1 \cdot p + (1-w_1)(1-p)) + (1-\omega)(w_2 \cdot p + (1-w_2) \cdot (1-p)) \\
&= \omega[(w_1-w_2) \cdot p + ((1-w_1) - (1-w_2))(1-p)] + w_2 \cdot p + (1-w_2) \cdot (1-p) \\
&= \omega[(w_1-w_2) \cdot p + (w_2-w_1) (1-p)] + w_2 \cdot p + (1-w_2) \cdot (1-p) \\
&= \omega[2p (w_1-w_2) + (w_2-w_1)] - 2p \left(\frac{1}{2} - w_2\right) - w_2 + 1.
\end{aligned}$$

Consequently,

$$\langle \bar{\omega} * W, \bar{p} \rangle = \frac{1}{2}$$

is satisfied if and only if

$$\omega = \frac{-\frac{1}{2} + w_2 + 2p \left(\frac{1}{2} - w_2\right)}{w_2 - w_1 + 2p (w_1 - w_2)}$$

<sup>2</sup>Nothing of essence is changed when multiplication with a permutation matrix is performed.

or, if

$$\omega = \frac{(w_2 - \frac{1}{2}) - 2p (w_2 - \frac{1}{2})}{(w_2 - w_1) - 2p (w_2 - w_1)}$$

which is alternatively given by

$$\begin{aligned} \omega &= \frac{(1-2p) (w_2 - \frac{1}{2})}{(1-2p) (w_2 - w_1)} \\ &= \frac{w_2 - \frac{1}{2}}{w_2 - w_1} \end{aligned}$$

Due to the regularity condition  $w_2 < \frac{1}{2} < w_1$  the solution  $\omega$  - independent of  $p$  - is contained in  $[0,1]$ . #

The solution is denoted as  $\omega^0$ , defining the vector  $\bar{\omega}^0 = (\omega^0, 1-\omega^0)$ .

A graphical representation may be found in the appendix, see figure 1.

Hereafter we shall assume that only two traders exist. The payoff-functions may now be given as

$$u(p,q) = \int_{\Omega} 1_{\{1\}}(f_{\omega}(\bar{p}, \bar{q})) [K - \langle \bar{\omega} * w^1, \bar{p} \rangle] \mu(d\omega)$$

and

$$v(p,q) = \int_{\Omega} 1_{\{2\}}(f_{\omega}(\bar{p}, \bar{q})) [K - \langle \bar{\omega} * w^2, \bar{q} \rangle] \mu(d\omega),$$

respectively.

Taking pattern from D. BLACKWELL [53] we use

### 3.4 Definition

$W$  is strictly more informative than  $\tilde{W}$  if there exists  $\tau \in [0,1]$  such that

$$\tilde{W} = W * \begin{pmatrix} 1-\tau & \tau \\ \tau & 1-\tau \end{pmatrix}$$

The matrix  $\begin{pmatrix} 1-\tau & \tau \\ \tau & 1-\tau \end{pmatrix}$  is called a garbling matrix by MARSCHAK and MIYASAWA [68].

Supposing the information structures to be comparable in the above sense it is conjectured that the two-players case is the only interesting one, in that it gives rise to the existence of non-degenerate equilibria. This makes the restriction on two players sound plausible.

### 3.5 Lemma

Suppose the regular information structure  $W_1$  to be strictly more informative than  $W_2$  and assume the garbling matrix to satisfy  $\tau < \frac{1}{2}$ . Then the regularity condition holds for  $W^2$  and  $W^2$  provides the same solution to the equality  $\langle \bar{\omega} * W^2, \bar{q} \rangle = \frac{1}{2}$  as  $W^1$  does.

#### Proof

Observe  $w_1^2 = (1-\tau) w_1^1 + \tau \cdot (1-w_1^1)$

and  $w_2^2 = (1-\tau) w_2^1 + \tau \cdot (1-w_2^1)$ .

Then the solution of the equality  $\langle \bar{\omega} * W^2, \bar{q} \rangle = \frac{1}{2}$  is given by

$$\begin{aligned} \omega^0 &= \frac{w_2^2 - \frac{1}{2}}{w_2^2 - w_1^2} \\ &= \frac{(1-\tau) w_2^1 + \tau \cdot (1-w_2^1) - \frac{1}{2}}{(1-\tau)(w_2^1 - w_1^1) + \tau((1-w_2^1) - (1-w_1^1))} \\ &= \frac{(1-2\tau) w_2^1 - \frac{1}{2} + \tau}{(1-2\tau)(w_2^1 - w_1^1)} \\ &= \frac{w_2^1 - \frac{1}{2}}{w_2^1 - w_1^1} \end{aligned}$$

which is the solution for the corresponding equality with respect to  $W^1$ . #

We shall show now that player 1 is slightly better off than player 2 under the restrictions of the preceding lemma. Recall

$$\langle \cdot * W, \bar{p} \rangle : \Delta(\mathcal{X}) \rightarrow \mathbb{R}$$

to be an affin-linear function, given any  $\bar{p} \in \Delta(\mathcal{X})$ . The set of all affin-linear function, induced by the fixed information structure  $W^1$ , obtainable by means of varying price-vectors  $\bar{p}$ , is denoted as  $\mathcal{F}_1$ .

$\mathcal{F}_1$  is obviously a convex set; moreover, it includes the set  $\mathcal{F}_2$  of functions which are derivable by player 2 by varying his strategy  $\bar{q}$ . Stated formally

3.6 Lemma

Assume  $W^2$  to satisfy the conditions of the preceding lemma. Then

$$\mathfrak{F}_2 \subset \mathfrak{F}_1.$$

Proof

First observe that  $\mathfrak{F}_1$  contains

$$g_1 = \langle \cdot * W_1^1 +, (1,0) \rangle, \text{ representable as}$$

$$\omega \rightarrow \omega \cdot W_1^1 + (1-\omega) \cdot W_2^1 \quad \text{and}$$

$$g_0 = \langle \cdot * W_1^1, (0,1) \rangle, \text{ representable as}$$

$$\omega \rightarrow \omega \cdot (1-W_1^1) + (1-\omega) \cdot (1-W_2^1).$$

Since  $\mathfrak{F}_1$  is convex it is sufficient to show that

$$\omega \rightarrow (\omega \cdot W_1^2 + (1-\omega) \cdot W_1^2) \cdot q + (\omega \cdot (1-W_1^2) + (1-\omega) \cdot (1-W_2^2)) \cdot (1-q)$$

may be obtained as a convex-combination of the functions given above.

However,

$$\begin{aligned} & (\omega \cdot W_1^2 + (1-\omega) \cdot W_2^2) \cdot q + (\omega \cdot (1-W_1^2) + (1-\omega) \cdot (1-W_2^2)) \cdot (1-q) \\ = & \{ \omega \cdot [(1-\tau) \cdot W_1^1 + \tau \cdot (1-W_1^1)] + (1-\omega) [(1-\tau) W_2^1 + \tau \cdot (1-W_2^1)] \} q \\ & + (1-\omega) [1 - ((1-\tau) W_1^1 + \tau (1-W_1^1))] + (1-\omega) [1 - ((1-\tau) W_2^1 + \tau \cdot (1-W_2^1))] \} (1-q) \\ = & (1-\tau) (q - (1-q)) [\omega \cdot W_1^1 + (1-\omega) \cdot W_2^1] \\ & + \tau \cdot (q - (1-q)) [\omega \cdot (1-W_1^1) + (1-\omega) (1-W_2^1)] + (\omega + (1-\omega)) \cdot (1-q) \end{aligned}$$

Since the terms in square brackets sum to one, we may find coincidence with

$$\begin{aligned} & ((1-\tau) \cdot (q - (1-q)) + (1-q)) [\omega \cdot W_1^1 + (1-\omega) W_2^1] \\ & + (\tau \cdot (q - (1-q)) + (1-q)) \cdot [\omega (1-W_1^1) + (1-\omega) (1-W_2^1)] \\ = & ((1-\tau) (2q-1) + (1-q)) [\omega \cdot W_1^1 + (1-\omega) \cdot W_2^1] \\ & + (\tau \cdot (2q-1) + (1-q)) [\omega \cdot (1-W_1^1) + (1-\omega) \cdot (1-W_2^1)] \end{aligned}$$

Since the coefficients in front of the square brackets are at least equal to zero and sum up to one, the claim follows. #

According to this lemma we may implicitly define an injective, isotonic function

$$f : \Delta(\mathcal{X}) \longrightarrow \Delta(\mathcal{X}).$$

This function is meant to satisfy the condition

$$\bigwedge_{\omega \in \Delta(\mathcal{X})} \langle \omega * W^2, \bar{q} \rangle = \langle \bar{\omega} * W^1, f(\bar{q}) \rangle,$$

or, to put it other way, the functions  $\langle \cdot * W^2, \bar{q} \rangle$  and  $\langle \cdot * W^1, \bar{p} \rangle$  coincide on  $\Delta(\mathcal{X})$ .

$f$  is easily seen to be affin-linear and satisfies  $0 < f(q) < 1$  for all  $q \in [0,1]$ , provided the garbling matrix satisfies  $r > 0$ . Its shape is roughly indicated in figure 2 (see appendix).

We shall now define functions

$$\bar{u}, \underline{u} : [0,1] \longrightarrow \mathbb{R}$$

and

$$\bar{v}, \underline{v} : [0,1] \longrightarrow \mathbb{R}$$

which will be proven to coincide with the payoff functions of the traders on the appropriate domain. The domain will be found to be characterized by the function  $f$  given above.

Define (what is meant to replace the payoff-function of player 1)

$$\bar{u}(p) = \int_{\{\bar{\omega} | \omega \geq \omega^0\}} K - \langle \bar{\omega} * W^1, \bar{p} \rangle \mu(d\omega)$$

and

$$\underline{u}(p) = \int_{\{\bar{\omega} | \omega \leq \omega^0\}} K - \langle \bar{\omega} * W^1, \bar{p} \rangle \mu(d\omega)$$

(For the definition of  $\omega^0$  compare lemma 3.3).

Functions related to player 2 are defined analogously,

$$\bar{v}(q) = \int_{\{\bar{\omega} | \omega \geq \omega^0\}} K - \langle \bar{\omega} * W^2, \bar{q} \rangle \mu(d\omega)$$

and

$$\underline{v}(q) = \int_{\{\bar{\omega} | \omega \leq \omega^0\}} K - \langle \bar{\omega} * W^2, \bar{q} \rangle \mu(d\omega).$$

For convenience we shall use a trivial extension of both functions to  $[0,1]^2$ , defined by

$$\wedge_q \bar{u}(p, q) = \bar{u}(p), \quad \underline{u}(p, q) = \underline{u}(p)$$

and, analogously,

$$\wedge_p \bar{v}(p, q) = \bar{v}(q), \quad \underline{v}(p, q) = \underline{v}(q),$$

no confusion shall arise from using the same symbol.

The function  $\bar{u}$ ,  $\underline{u}$  and  $\bar{v}$ ,  $\underline{v}$  are immediately found to be affin-linear, their graphs define hyperplanes within  $\mathbb{R}^3$ .

Moreover it is observed that  $\bar{u}$  and  $\bar{v}$  are strictly antitonic<sup>3</sup> as functions of  $p$  and  $q$ , respectively. Analogously,  $\underline{u}$  and  $\underline{v}$  are strictly isotonic in  $p$  and  $q$ , respectively. A sketch of the graphs is given in the appendix, figures 3a to 3d.

By means of these function we can give an alternative description of the payoff-functions  $u$  and  $v$  of the players.

Using the definition of  $f$  we infer in case of  $p > f(q)$

$$\wedge_{\substack{\bar{\omega} \\ \omega \geq \omega^0}} \langle \bar{\omega} * W^1, \bar{p} \rangle \geq \langle \bar{\omega} * W^2, \bar{q} \rangle$$

and

$$\wedge_{\substack{\bar{\omega} \\ \omega \leq \omega^0}} \langle \bar{\omega} * W^1, \bar{p} \rangle \leq \langle \bar{\omega} * W^2, \bar{q} \rangle.$$

---

<sup>3</sup>Remember the regularity condition  $w_1 > \frac{1}{2} > w_2$ .

Consequently for  $p > f(q)$

$$u(p, q) = \bar{u}(p, q) = \bar{u}(p)$$

and

$$v(p, q) = \underline{v}(p, q) = \underline{v}(q).$$

In case of the opposite relationship we find

$$u(p, q) = \underline{u}(p, q) = \underline{u}(p)$$

and

$$v(p, q) = \bar{v}(p, q) = \bar{v}(q).$$

A representative sketch<sup>4</sup> of the graphs of  $u$  and  $v$  may be found in figures 4.a and 4.b (see appendix).

It remains to consider the case  $p = f(q)$ . The sellers now being indifferent with respect to the sellers, we find

$$u(p, q) = \frac{1}{2} (\bar{u}(p, q) + \underline{u}(p, q))$$

and

$$v(p, q) = \frac{1}{2} (\bar{v}(p, q) + \underline{v}(p, q)).$$

The assumption of comparable information structures in the sense of definition 3.4 imposes the characteristic feature on the functions  $u$  and  $v$ . Within the next lemma we shall establish the existence of a pair of strategies  $(p^*, q^*)$ , later on being identified as a non-degenerate  $\epsilon$ -equilibrium.

### 3.7 Lemma

Assume the existence of  $q^* \in [0, 1]$  satisfying  $\bar{v}(q^*) = \underline{v}(q^*)$ . Then

there exists  $p^* \in [0, 1]$  such that

$$\bar{u}(p^*) = \underline{u}(p^*) = \bar{v}(q^*) = \underline{v}(q^*).$$

---

<sup>4</sup>It may occur that the graphs of  $\bar{u}$  and  $\underline{u}$  as well as those of  $\bar{v}$  and  $\underline{v}$  have no point in common.



Proof

Define  $p^* = f(q^*)$ . Then

$$\begin{aligned}
 \bar{u}(p^*) &= \int_{\{\bar{\omega} | \omega \geq \omega^0\}} K - \langle \bar{\omega} * W^1, \bar{p}^* \rangle \mu(d\omega) \\
 &= \int_{\{\bar{\omega} | \omega \geq \omega^0\}} K - \langle \bar{\omega} * W^2, \bar{q}^* \rangle \mu(d\omega) \\
 &= \bar{v}(q^*) \\
 &= \underline{v}(q^*) \\
 &= \int_{\{\bar{\omega} | \omega \leq \omega^0\}} K - \langle \bar{\omega} * W^2, \bar{q}^* \rangle \mu(d\omega) \\
 &= \int_{\{\bar{\omega} | \omega \leq \omega^0\}} K - \langle \bar{\omega} * W^1, \bar{p}^* \rangle \mu(d\omega) \\
 &= \underline{u}(p^*) \quad \#
 \end{aligned}$$

A strategy  $q^*$  as presupposed by the preceding lemma induces player 2 to be indifferent between absorbing clients satisfying  $\omega \leq \omega^0$  or  $\omega \geq \omega^0$ , since the accumulated payoffs to both groups are equal to one another. Its existence heavily depends on the number  $K$ . In fact, assume  $\mu = \lambda$  (Lebesgue measure). Thens the equality

$$\int_{\{\bar{\omega} | \omega \geq \omega^0\}} K - \langle \bar{\omega} * W^2, \bar{q}^* \rangle \mu(d\omega) = \int_{\{\bar{\omega} | \omega \leq \omega^0\}} K - \langle \bar{\omega} * W^2, \bar{q}^* \rangle \mu(d\omega)$$

holds if and only if

$$\begin{aligned}
 &K \cdot (\lambda(\{\bar{\omega} | \omega \geq \omega^0\}) - 1) \\
 &= \int_{\{\bar{\omega} | \omega \leq \omega^0\}} \langle \bar{\omega} * W^2, \bar{q} \rangle \mu(d\omega) - \int_{\{\bar{\omega} | \omega \geq \omega^0\}} \langle \bar{\omega} * W^2, \bar{q} \rangle \mu(d\omega)
 \end{aligned}$$

Let us denote the latter expression, as function depending on  $q$ , as  $h(q)$ .

It is easily seen that  $h$  is an isotonic function if  $\omega^0 \leq \frac{1}{2}$  and it is anti-tonic provides the relation  $\omega^0 \geq \frac{1}{2}$  holds. Consequently

$$\begin{aligned}
 \bar{h}(q) &= (2\lambda(\{\bar{\omega} | \omega \geq \omega^0\}) - 1)^{-1} \\
 &\cdot \left( \int_{\{\bar{\omega} | \omega \leq \omega^0\}} \langle \bar{\omega} * W^2, \bar{q} \rangle \mu(d\omega) - \int_{\{\bar{\omega} | \omega \geq \omega^0\}} \langle \bar{\omega} * W^2, \bar{q} \rangle \mu(d\omega) \right)
 \end{aligned}$$

is isotonic with respect to  $q$ . Let  $\underline{p}$  denote its minimum and  $\bar{p}$  its maximum value. Then according to the continuity of  $\bar{h}$  a price-vector  $q$ , satisfying the presuppositions of the preceding lemma, exists, provided  $K \in [\underline{p}, \bar{p}]$ .

### 3.8 Definition

Let  $\epsilon > 0$  be given. Strategies  $(p^*, q^*)$  are termed  $\epsilon$ -equilibrium strategies if

$$\bigwedge_p u(p, q^*) \leq u(p^*, q^*) + \epsilon$$

and

$$\bigwedge_q v(p^*, q) \leq v(p^*, q^*) + \epsilon$$

Payoffs  $(\alpha, \beta) \in \mathbb{R}^2$  are denoted as  $\epsilon$ -equilibrium payoffs if there exist  $\epsilon$ -equilibrium strategies  $(p^*, q^*)$  such that

$$(u(p^*, q^*), v(p^*, q^*)) = (\alpha, \beta)$$

The above lemma will be shown to guarantee the existence of  $\epsilon$ -equilibria under the restriction  $\bar{v}(q^*) = \underline{v}(q^*)$ . But more than this is true. The subsequent theorem ensures the existence of  $\epsilon$ -equilibria also when the above assumption fails. In that case  $\epsilon$ -equilibria will be found to be given by the extreme strategies  $q^* = 0$  (or  $q^* = 1$ ) or even by  $q^* = p^* = 0$  (or  $q^* = p^* = 1$ ). Those  $\epsilon$ -equilibrium strategies will be called degenerate.

### 3.9 Theorem

Suppose  $\epsilon > 0$ . Suppose  $W^1$  to satisfy the regularity condition and  $W^2$  to be obtained using a garbling matrix for some  $0 < \tau < \frac{1}{2}$

Then an  $\epsilon$ -equilibrium exists. More specifically, the  $\epsilon$ -equilibrium satisfies

$$(i) \quad q^*, p^* = f(q^*) \in (0, 1),$$

$$\text{if } \bar{v}(q^*) = \underline{v}(q^*) \text{ for some } q^* \in (0, 1)$$

$$(ii) \quad q^* = 1, p^* \in \{f(1) + \delta' / 0 < \delta' \leq \delta(\epsilon)\}$$

$$\text{if } \bigwedge_q \bar{v}(q) \geq \underline{v}(q)$$

$$(iii) \quad q^* = 0, p^* \in \{f(0) - \delta' / 0 < \delta' \leq \delta(\epsilon)\}$$

$$\text{if } \bigwedge_q \bar{v}(q) \leq \underline{v}(q).$$

**Proof**

Assume  $\bar{v}(q^*) = \underline{v}(q^*)$  for some  $q^* \in (0,1)$ . According to lemma 3.7 we may find  $p^* (= f(q^*))$  such that

$$\bar{v}(q^*) = \underline{v}(q^*) = \bar{u}(p^*) = \underline{u}(q^*).$$

We claim  $(p^*, q^*)$  to be an  $\epsilon$ -equilibrium. Indeed, assume that player 1 deviates using  $p > p^*$ . Then

$$\begin{aligned} u(p^*, q^*) &= \frac{1}{2} (\bar{u}(p^*, q^*) + \underline{u}(p^*, q^*)) = \bar{u}(p^*, q^*) \\ &> \bar{u}(p, q^*) \\ &= u(p, q^*), \end{aligned}$$

the inequality follows from  $\bar{u}$  being a strictly antitonic function. The second mode of deviation does not pay either. For any  $p < p^*$  we find

$$\begin{aligned} u(p^*, q^*) &= \frac{1}{2} (\bar{u}(p^*, q^*) + \underline{u}(p^*, q^*)) \\ &= \underline{u}(p^*, q^*) \\ &> \underline{u}(p, q^*) \\ &= u(p, q^*), \end{aligned}$$

here strict isotonicity of  $\underline{u}$  is used.

This proves that no incentive for deviation exists as far as player 1 is concerned. Of course in case of player 2 the argument is comparable. Thus in this specific case the existence even of a 0-equilibrium has been proven.

It remains to tackle the case

$$\bar{v}(q) \neq \underline{v}(q)$$

for all  $q$ .

We may assume  $\bigwedge_q \bar{v}(q) > \underline{v}(q)$ , the argument in the reverse case will be identical.

Due to our assumption

$$\bar{u}(f(q), q) = \bar{v}(f(q), q) > \underline{v}(f(q), q) = \underline{u}(f(q), q).$$

Let  $\delta > 0$  be given and define  $p = f(q) + \delta$ . Then supposing  $\delta$  to be sufficiently small we infer from the continuity of  $\bar{u}$ :

$$\begin{aligned} u(p, q) &= u(f(q) + \delta, q) \\ &= \bar{u}(f(q) + \delta, q) \\ &\geq \bar{u}(f(q), q) - \epsilon \\ &> \frac{1}{2} (\bar{u}(f(q), q) + \underline{v}(f(q), q)) - \epsilon \\ &= \frac{1}{2} (\bar{u}(f(q), q) + \underline{u}(f(q), q)) - \epsilon \\ &= u(f(q), q) - \epsilon. \end{aligned}$$

Consequently, as far as player 1 is concerned, equilibrium strategies have to satisfy the condition  $p > f(q)$ , which is available for any  $q$ , since  $\wedge_q f(q) < 1$  due to the assumption  $\tau > 0$  on the garbling matrix.

Anticipating this behavior of player 1 player 2 is faced with the payoff-function

$$v(p, q) = \underline{v}(p, q).$$

This function being strictly isotonic with respect to  $q$  he chooses  $q^* = 1$ . Thus  $\epsilon$ -equilibria are found to be given by

$$\{(f(1) + \delta', 1) / 0 < \delta' \leq \delta\}$$

for sufficiently small  $\delta = \delta(\epsilon)$ .

A comparable argument shows

$$(p, q) \in \{(f(0) - \delta', 0) / 0 < \delta' \leq \delta\}$$

to be an  $\epsilon$ -equilibrium in case of  $\wedge_q \bar{v}(q) \leq \underline{v}(q)$ . #

**Remark**

Let us provide the general observation that pairs  $(p, q)$  satisfying  $|p - f(q)| > \delta$  will not be  $\epsilon$ -equilibria, where  $\delta = \delta(\epsilon)$ . Indeed, for  $p < f(q) - \delta$  the payoff function  $u$  is equal to  $\underline{u}$  and any deviation  $p' = p + \delta$  towards  $f(q)$  pays for player 1 by more than  $\epsilon$ . On the other hand, for  $p > f(q) + \delta$  player 1 receives a better payoff when he deviates to  $p' = p - \delta$ , since in that case  $u = \bar{u}$  which is known to be an antitonic function.

Thus  $\epsilon$ -equilibrium pairs  $(p, q)$  satisfy

$$|p - f(q)| < \delta.$$

From the above remark and the proof of the theorem we infer that degenerate  $\epsilon$ -equilibria are "unique".

Uniqueness of the non-degenerate 0-equilibrium will follow from observing

$$v(f(q), q) = \frac{1}{2} (\bar{v}(f(q), q) + \underline{v}(f(q), q))$$

$$\leq \begin{cases} \bar{v}(f(q), q + \delta) & \text{if } \bar{v}(f(q), q) > \underline{v}(f(q), q) \\ \underline{v}(f(q), q - \delta) & \text{if } \bar{v}(f(q), q) < \underline{v}(f(q), q) \end{cases}$$

yielding  $q^*$  satisfying  $\bar{v}(q^*) = \underline{v}(q^*)$  to be used by player 2, whenever possible.

Anticipating this, player 1 has to choose  $p^* = f(q^*)$ , since for  $p > f(q^*)$

$$u(p, q^*) = \bar{u}(p, q^*) < \bar{u}(p^*, q^*)$$

$$= \frac{1}{2} (\bar{u}(p^*, q^*) + \underline{u}(p^*, q^*))$$

$$= u(p^*, q^*)$$

and, analogously for  $p < f(q^*)$ :

$$u(p, q^*) = \underline{u}(p, q^*) < \underline{u}(p^*, q^*)$$

$$= \frac{1}{2} (\underline{u}(p^*, q^*) + \bar{u}(p^*, q^*))$$

$$= u(p^*, q^*),$$

whence unicity of the 0-equilibrium in the non-degenerate case.

Appendix

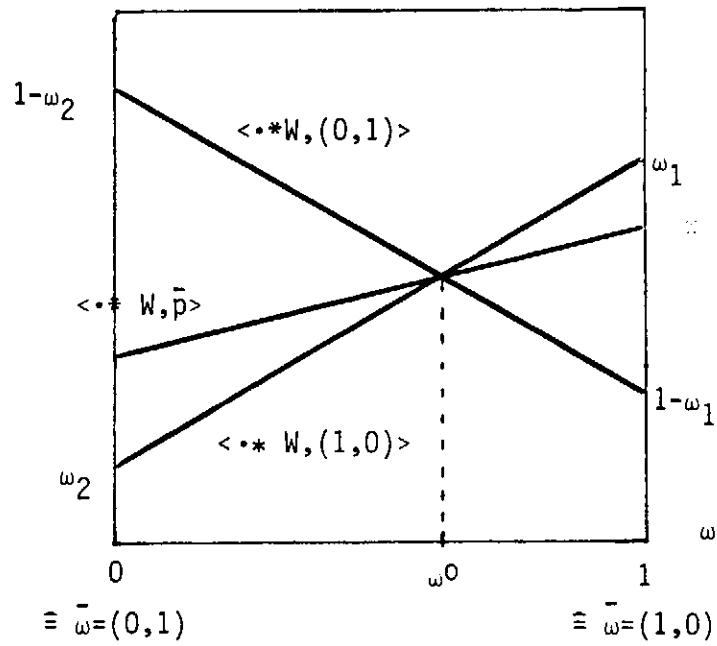

figure 1

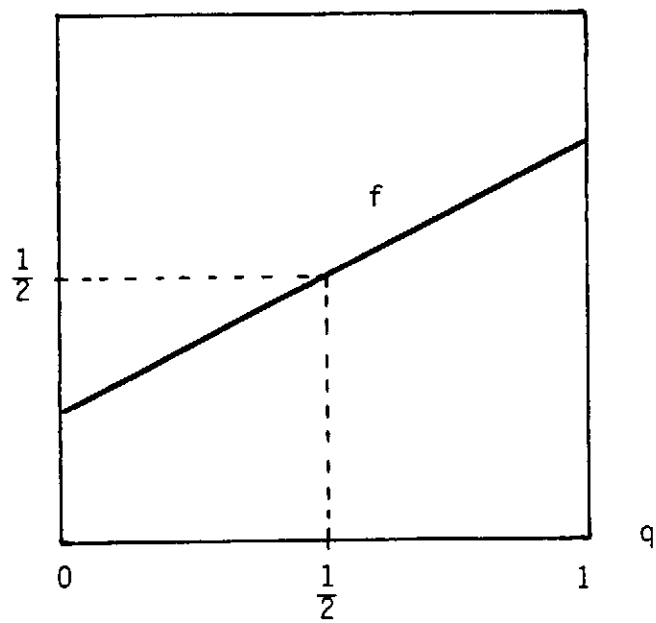

figure 2

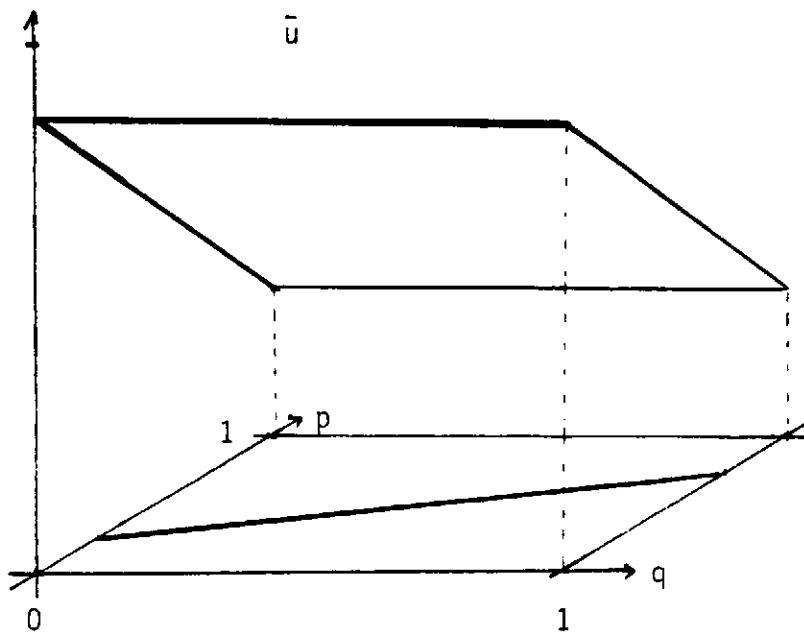

figure 3a

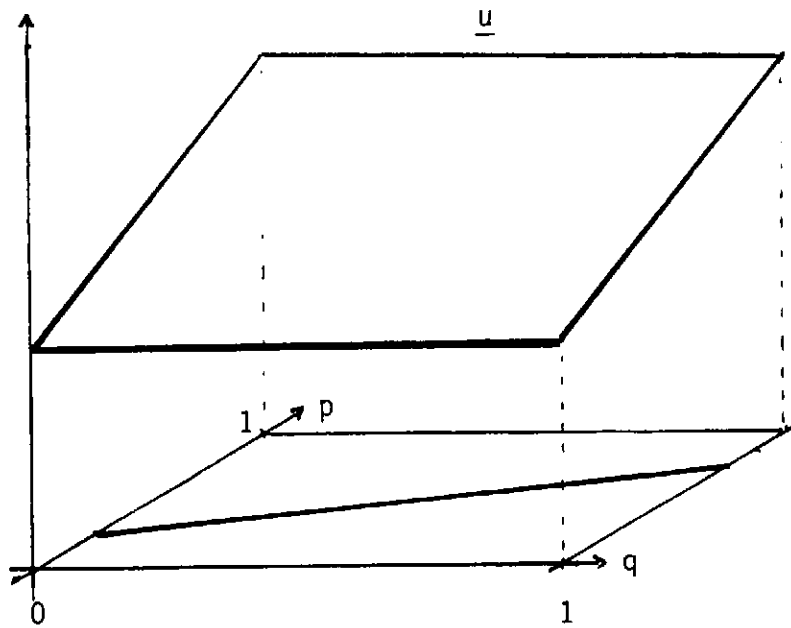

figure 3b

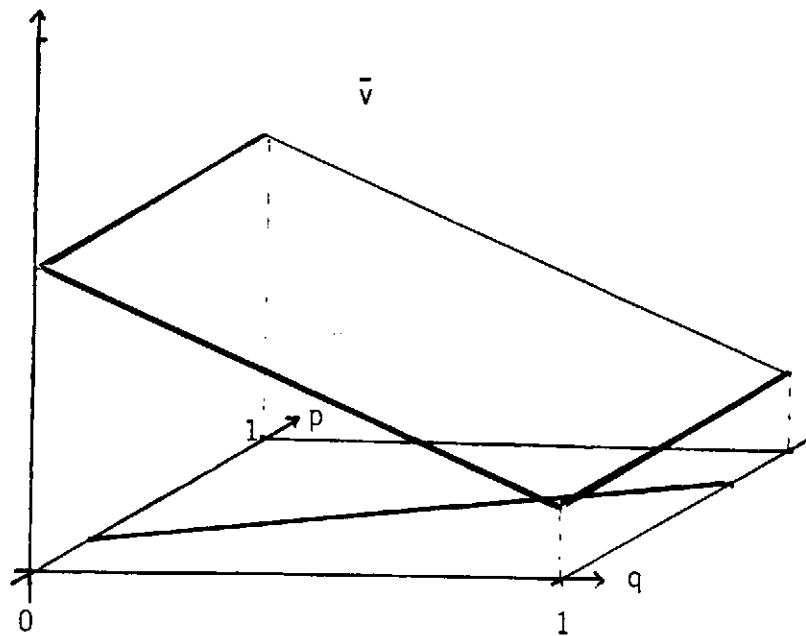

figure 3c

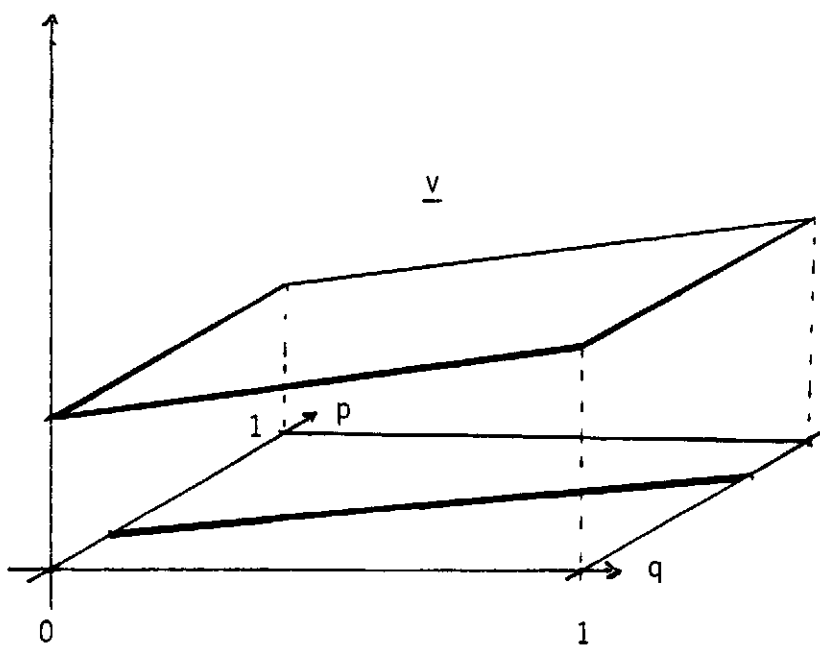

figure 3d



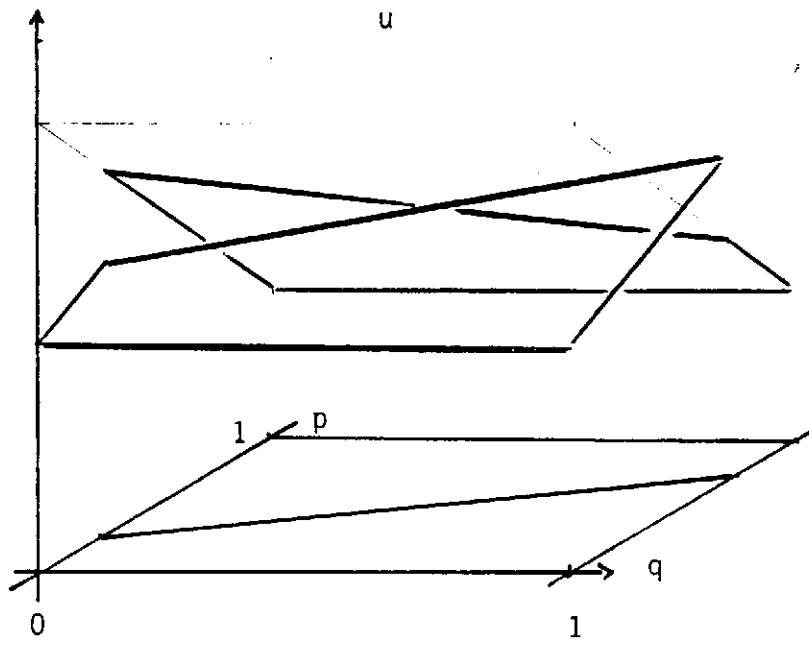

figure 4a

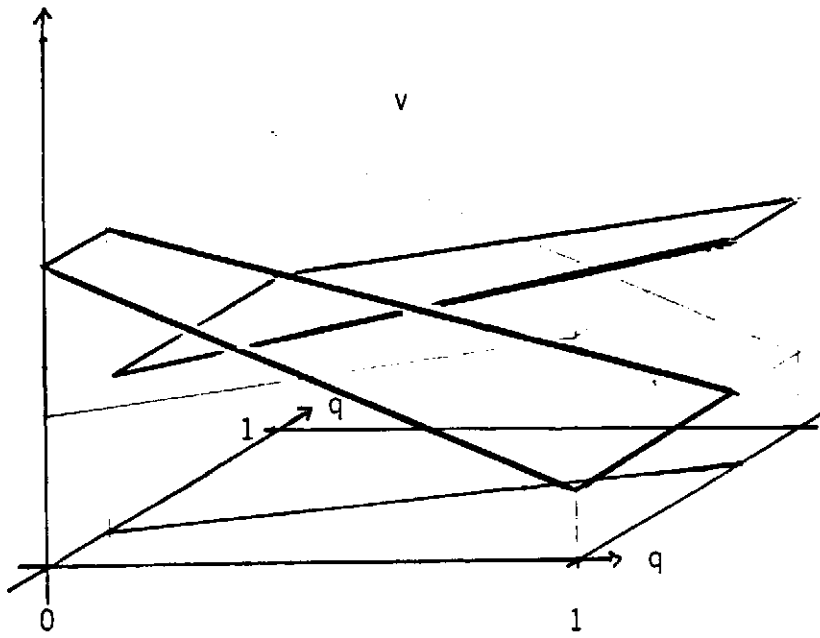

figure 4b

## References

- [86] Bester, H.: Non-Cooperative Bargaining and Spatial Competition. Discussion Paper No. A-73, University of Bonn, (1986).
- [53] Blackwell, D.: Equivalent Comparisons of Experiments, Ann.Math.Statistics, 24, (1953).
- [79] Hirshleifer, J. The Analytics of Uncertainty and Information - An and J.Riley: Expository Survey, J.Econ.Lit.17, (1979).
- [72] Marschak, T. Economic Theory of Teams, Yale University Press, and R.Radner: (1972).
- [82] Nermuth, M.: Information Structures in Economics, Berlin, (1982).