

Lecture notes on stabilization of contact open books

Otto van Koert

(Communicated by Linus Kramer)

Abstract. This note explains how to relate some contact geometric operations, such as surgery, to operations on an underlying contact open book. In particular, we shall give a simple proof of the fact that stabilizations of contact open books yield contactomorphic manifolds.

1. INTRODUCTION

The correspondence between open books and contact structures as established by Giroux [11] has been extremely fruitful in understanding contact structures both in dimension 3 and in higher dimensions.

In general, this correspondence looks as follows. Given a Weinstein manifold W and a symplectomorphism ψ of W that is the identity near ∂W , we can endow the mapping torus of (W, ψ) with a natural contact form. The boundary of this mapping torus is diffeomorphic to $\partial W \times S^1$, which allows us to glue in a copy of $\partial W \times D^2$. The latter set can be given a contact form which glues nicely to the one on the mapping torus.

Conversely, every compact coorientable contact manifold can in fact be obtained by this construction. However, such supporting open books for contact manifolds are not unique. For instance, one has a stabilization procedure, which does not change the contact structure, but it does change the open book. Suppose we are given a contact open book $\text{OB}(W, \psi)$ with a Lagrangian disk L in a page W such that ∂L is a Legendrian sphere in ∂W . We obtain a new page \widetilde{W} by attaching a symplectic handle to W along ∂L . The monodromy ψ can be extended as the identity on the symplectic handle. Since \widetilde{W} contains a Lagrangian sphere formed by L and the core of the symplectic handle, we can compose the monodromy ψ with a right-handed Dehn twist τ_L along this Lagrangian sphere. This leads us to the (positive) stabilization of $\text{OB}(W, \psi)$,

This work was partially supported by NRF grant NRF-2016R1C1B2007662, funded by the Korean government.

which is given by $\text{OB}(\widetilde{W}, \tau_L \circ \psi)$. According to Giroux the stabilization is contactomorphic to the original contact manifold. This result has been used in numerous papers, and is of particular importance for understanding fillability. We mention the diagrammatic description of contact 5-manifolds in [7], the infinite order of nontrivial compositions of right-handed symplectic Dehn twists in arbitrary higher-dimensional Liouville manifolds in [3], and the construction of infinitely many distinct Stein fillings of certain higher-dimensional contact manifolds in [19].

In dimension 3 the above correspondence is even better. Giroux has shown that on a compact, orientable 3-manifold M , open books for M up to (positive) stabilization correspond bijectively to isotopy classes of contact structures on M .

The goal of this note is to clarify some of these well-known notions and to provide proofs for some of them. We shall discuss the relation between contact surgery and open books: in Proposition 4.2 we will see that subcritical handle attachment along isotropic spheres in the binding can be seen as handle attachment to the page of the open book, whereas Theorem 4.6 shows that Legendrian surgery along a Legendrian sphere L in a page can be seen as composing the initial monodromy with a right-handed Dehn twist along L . This implies the well-known assertion, made in Proposition 4.7, that a contact open book whose monodromy is isotopic to the product of right-handed Dehn twists is Stein fillable. We also provide a proof of the fact that stabilization does not change the contact structure. This is the statement of Proposition 4.13.

Our proofs are elementary and work almost entirely in the contact world. In particular, we shall not use Lefschetz fibrations, which could be used to look at the situation from another point of view in case the contact manifold arises as the boundary of an exact Lefschetz fibration. Such a point of view is taken in [16, App. A]. The short idea of the proof in our setting is to interpret the handle attachment to the page and change of monodromy as successive contact surgeries which cancel each other. To see the latter, we use symplectic handle cancellation.

2. WEINSTEIN MANIFOLDS AND OPEN BOOKS

2.1. Weinstein and Stein. Let us first define the notion of Weinstein manifold.

Definition 2.2. Let M be a smooth manifold, and let $f : M \rightarrow \mathbb{R}$ be a smooth function. A vector field X on M is called *gradient-like* for the function f if $\mathcal{L}_X f > 0$ outside the critical points of f .

Definition 2.3. Let (W, ω) be a symplectic manifold. A proper function $f : W \rightarrow [0, \infty)$ is called ω -convex if it admits a complete gradient-like Liouville vector field X , i.e. $\mathcal{L}_X \omega = \omega$. We say (W, ω) is a *Weinstein manifold* if there exists an ω -convex Morse function. Call (W, ω) of *finite type* if there is an ω -convex Morse function with only finitely many critical points.

Remark 2.4. The ends of a Weinstein manifold of finite type are convex, i.e. they look like the positive ends of a symplectization. Indeed, let f be an ω -convex function with finitely many critical points and X a complete gradient-like Liouville vector field for f .

Finite type means that all critical points are contained in the interior of some compact set $K = f^{-1}(]-\infty, c])$. The boundary of K is a smooth contact manifold since it is the level set of a regular value of f , and the Liouville vector field is transverse by the gradient-like condition, so $i_X\omega$ restricts to a contact form. Furthermore, the vector field X is non-vanishing on $W - K$ and complete, so we obtain the symplectomorphism

$$[0, \infty) \times \partial K \rightarrow W - \text{int}(K), \quad (t, k) \mapsto Fl_t^X(i(k)),$$

which shows the claim.

From now on, whenever we talk about Weinstein manifolds we mean Weinstein manifolds of finite type.

Remark 2.5. We shall also apply the definition of ω -convex function to general symplectic cobordisms. In such a case the function f may not be bounded from below. The most basic example is a symplectization $(\mathbb{R} \times M, \omega = d(e^t\alpha))$, where the function $f(t, x) = e^t$ is ω -convex for $X = \frac{\partial}{\partial t}$.

Note that $i_X\omega$ defines a primitive of ω , so Weinstein manifolds are exact symplectic. For the sake of completeness, let us briefly recall some related notions.

Definition 2.6. Let (W, J) be an almost complex manifold. A smooth function $f : W \rightarrow \mathbb{R}$ is said to be *strictly plurisubharmonic* if

$$-d(df \circ J)(X, JX) > 0$$

for all nonzero vectors X .

Remark 2.7. The motivation behind this definition is that a holomorphic curve C in (W, J) will have the property that $f|_C$ is subharmonic. In other words, f satisfies a maximum principle on every holomorphic curve.

The most basic example of a plurisubharmonic function is $f : z \mapsto \|z\|^2$ on \mathbb{C}^n . In this case the formula $-d(df \circ J)(\cdot, J\cdot)$ yields a Riemannian metric.

We briefly want to point out a relation between Weinstein and Stein manifolds, a notion in complex geometry and several complex variables. Recall that *Stein manifolds* can be defined as those complex manifolds that admit a proper holomorphic embedding into \mathbb{C}^n . By a theorem of Grauert, a complex manifold (W, J) is Stein if and only if it admits a strictly plurisubharmonic function f . One implication is not difficult: given a Stein manifold embedded in \mathbb{C}^n , one can take the basic example $f : W \rightarrow \mathbb{R}, z \mapsto \|z\|^2$. The converse is much harder, see Grauert’s paper [14] or [15, Chap. IX] for an exposition of this result.

Denote the associated symplectic form $-d(df \circ J)$ on W by ω_f . We then see that strictly plurisubharmonic functions on Stein manifolds are examples

of ω_f -convex functions, i.e. Stein manifolds are Weinstein. Indeed, by solving the equation

$$i_X \omega_f = -df \circ J,$$

we obtain a Liouville vector field that is gradient-like for f , as $0 \leq \omega_f(X, JX) = df(X)$.

According to a fundamental result due to Eliashberg the following converse is also true.

Theorem 2.8 (Eliashberg). *Given a Weinstein manifold (W, ω) with ω -convex Morse function f , there is an integrable complex structure J making (W, J) into a Stein manifold with strictly plurisubharmonic function f . Furthermore, (W, ω_f, f) is Weinstein-homotopic to (W, ω, f) with fixed function f .*

In this particular theorem, a Weinstein-homotopy with a fixed Morse function f can be defined as a homotopy of the symplectic forms ω_s such that the associated gradient-like Liouville vector field is outward pointing for some smooth family of exhaustions $\bigcup_{k=1}^{\infty} W_s^k$ of the manifold W .

This theorem and the related notions are explained in detail in the monograph [6]. However, we are only interested in the exact symplectic structure rather than the complex structure, we shall formulate everything using Weinstein and Liouville domains.

Definition 2.9. A *compact Weinstein manifold* or *Weinstein domain* (Σ, ω) is a compact symplectic manifold with boundary K that can be embedded into a Weinstein manifold (W, ω) with an ω -convex function f such that Σ is given as the preimage $f^{-1}([0, C])$, and such that C is a regular level set of f . By a *Liouville domain* we mean an exact, compact symplectic manifold (Σ, ω) with globally defined Liouville vector field X that points outward along the boundary of Σ .

Definition 2.10. We will call a boundary component of a symplectic manifold *convex* if the Liouville vector field points outward and *concave* if the Liouville vector field points inward.

We already mentioned in Remark 2.4 and now stress that by definition the boundary of a Weinstein domain is automatically a contact manifold. Furthermore, a Liouville domain is a generalization of a Weinstein domain that may not carry an ω -convex Morse function. This means that we do not obtain good control on the topology of Liouville domains, which we do get in the case of Weinstein domains. For example, a Weinstein domain of real dimension $2n$ has the homotopy type of a CW-complex of dimension n , as explained for example in the monograph [6, Cor. 3.4].

2.11. Contact open books.

Definition 2.12. An *abstract (contact) open book* (Σ, λ, ψ) consists of a Liouville domain $(\Sigma, d\lambda)$, and a symplectomorphism $\psi : \Sigma \rightarrow \Sigma$ with compact support such that $\psi^* d\lambda = d\lambda$.

Let us now show that an abstract contact open book corresponds to a contact manifold with a supporting open book. By a lemma of Giroux [12] we can assume that $\psi^*\lambda = \lambda - dU$. We choose the function U to be *negative*. For completeness, here is the lemma and a proof.

Lemma 2.13 (Giroux). *The symplectomorphism ψ can be isotoped to a symplectomorphism $\widehat{\psi}$ that is the identity near the boundary and that satisfies*

$$\widehat{\psi}^*\lambda = \lambda - dU.$$

Proof. Let us denote the 1-form $\psi^*\lambda - \lambda$ by μ . Since $d\lambda$ is non-degenerate, we find a unique solution Y to the equation $i_Y d\lambda = -\mu$. The flow of the vector field Y preserves $d\lambda$, because μ is closed,

$$\mathcal{L}_Y d\lambda = dt_Y d\lambda = -d\mu = 0.$$

Since ψ is the identity near the boundary, μ and hence Y vanishes near the boundary. If we denote the time- t flow of Y by φ_t , then we see that $\widehat{\psi} = \psi \circ \varphi_1$ is a symplectomorphism that is the identity near the boundary. Note that $\mathcal{L}_Y \mu = 0$, so $\varphi_t^* \mu = \mu$ for all t . We check that the difference of the pullback of λ and λ is indeed exact. We have

$$(\psi \circ \varphi_1)^*\lambda - \lambda = \varphi_1^*(\mu + \lambda) - \lambda = \mu + \varphi_1^*\lambda - \lambda.$$

On the other hand, we can express the difference $\varphi_1^*\lambda - \lambda$ as

$$\begin{aligned} \varphi_1^*\lambda - \lambda &= \int_0^1 \frac{d}{dt} \varphi_t^*\lambda dt = \int_0^1 (\varphi_t^* \mathcal{L}_Y \lambda) dt = \int_0^1 \varphi_t^*(i_Y d\lambda + d(i_Y \lambda)) dt \\ &= -\mu + d \int_0^1 \varphi_t^*(i_Y \lambda) dt. \end{aligned}$$

Moving μ to the left-hand side, we see that $\mu + \varphi_1^*\lambda - \lambda$ is exact, which shows the claim of the lemma. □

Now we can define

$$A_{(\Sigma, \psi)} := \Sigma \times \mathbb{R} / (x, \varphi) \sim (\psi(x), \varphi + U(x)).$$

This mapping torus carries the contact form

$$\alpha = \lambda + d\varphi.$$

Since ψ is the identity near the boundary of Σ , a neighborhood of the boundary looks like

$$\left] -\frac{1}{2}, 0 \right] \times \partial\Sigma \times S^1,$$

with contact form

$$\alpha = e^r \lambda_{\partial\Sigma} + d\varphi.$$

Here we write $\lambda_{\partial\Sigma} := i^*\lambda$, where $i : \partial\Sigma \rightarrow \Sigma$ is the inclusion. Denote the annulus $\{z \in \mathbb{C} \mid r < |z| < R\}$ by $A(r, R)$. We can glue the mapping torus $A_{(\Sigma, \psi)}$ along its boundary to

$$B_\Sigma := \partial\Sigma \times D^2$$

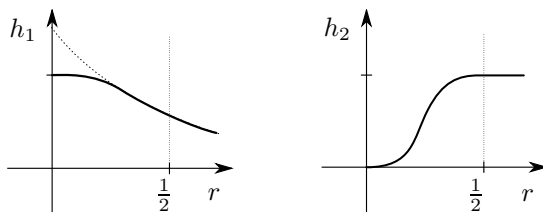

FIGURE 1. Functions for the contact form near the binding.

using the map

$$\begin{aligned} \Phi_{\text{glue}} : \partial\Sigma \times A(1/2, 1) &\rightarrow]-1/2, 0] \times \partial\Sigma \times S^1, \\ (x; r e^{i\varphi}) &\mapsto (1/2 - r, x, \varphi). \end{aligned}$$

Pulling back the form α by Φ_{glue} , we obtain

$$e^{1/2-r} \lambda_{\partial\Sigma} + d\varphi$$

on $\Sigma \times A(1/2, 1)$, which can be easily extended to a contact form

$$\beta = h_1(r) \lambda_{\partial\Sigma} + h_2(r) d\varphi$$

on the interior of B_Σ by requiring that h_1 and h_2 are functions from $[0, 1]$ to \mathbb{R} whose behavior is indicated in Figure 1; for us $h_1(r)$ should have exponential drop-off and $h_2(r)$ should quadratically increase near 0 and be constant near 1. Other profiles can also be used.

The union $M := A_{(\Sigma, \psi)} \cup_{\partial} B_\Sigma$ is called an *abstract open book* for M . Note that the contact forms α on $A_{(\Sigma, \psi)}$ and β on B_Σ glue together to a globally defined contact form.

We shall call the resulting contact manifold, which we denote by $\text{OB}(\Sigma, \lambda; \psi)$, a *contact open book*. We shall sometimes drop the primitive λ of the symplectic form in our later notation.

Definition 2.14. A *concrete open book* or just *open book* on M is a pair (B, ϑ) , where

- (i) B is a codimension-2 submanifold of M with trivial normal bundle, and
- (ii) $\vartheta : M - B \rightarrow S^1$ endows $M - B$ with the structure of a fiber bundle over S^1 such that ϑ gives the angular coordinate of the D^2 -factor of a neighborhood $B \times D^2$ of B .

The set B is called the *binding* of the open book. The closure of a fiber of ϑ is called a *page* of the open book.

Remark 2.15. A typical example of an open book is that of a so-called fibered knot in a 3-manifold. The adjective fibered means that the knot complement fibers over the circle. This is equivalent to an open book. A well-known example is the unknot in S^3 .

2.15.1. *Relation between abstract and concrete open books: monodromy.* First of all we observe that an abstract open book carries the structure of a concrete open book. Indeed, the manifold $\text{OB}(\Sigma, \lambda; \psi)$ has the structure of a fibration over S^1 away from the set B . If we disregard the contact structure for now, we can rescale U , which is assumed to be negative, to -2π , so we may put

$$\vartheta : \text{OB}(\Sigma, \psi) - \partial\Sigma = A_{(\Sigma, \psi)} \rightarrow S^1 = \mathbb{R}/2\pi\mathbb{Z}, \quad [x, t] \mapsto [t].$$

The corresponding statement in the contact setting is in Proposition 2.18. This needs an additional definition, which we will see in the next section. To go from a concrete open book (B, ϑ) on M to an abstract open book, we first need to define the monodromy.

We now describe how to do this smoothly. By part (ii) of the definition we can choose a Riemannian metric such that the fibers of ϑ are orthogonal to the vector field ∂_φ on the set $\nu_M(B) - B \cong B \times (D^2 - \{0\})$. Here we are using polar coordinates (r, φ) on the disk factor D^2 . Extend this metric in any way, and define a smooth connection by the following rule:

- The vertical spaces Vert are the tangent spaces to the fibers $\vartheta^{-1}([t])$.
- The horizontal spaces Hor are the orthogonal complement with respect to the metric we just chose.

To define the smooth monodromy of a concrete open book, we consider the loop $t \mapsto e^{it}$ in S^1 . We lift the tangent vector field to this loop, given by ∂_φ , to a horizontal vector field X_M on M . Note that this vector field X_M equals ∂_φ near the binding B . The *smooth monodromy* of the open book is the time- 2π flow of this vector field X_M .

In other words, the map ψ we used in the abstract open book $\text{OB}(\Sigma, \psi)$ is the monodromy. Indeed, on the mapping torus we use the obvious lift to find $[x, 0] \mapsto [x, 2\pi] = [\psi(x), 0]$, which tells us that the monodromy is given by ψ .

We should also point out that there are various conventions in use at this point. Some papers refer to ψ^{-1} as the monodromy, and Milnor [18] used the word *characteristic homeomorphism* for a related notion, where the boundary is not fixed.

2.15.2. *Adapted open books.* In order to define the notion of adapted open book, we need to discuss the orientations involved. Suppose M is an oriented manifold with an open book (B, ϑ) . Since we regard S^1 as an oriented manifold, each page Σ gets an induced orientation such that the orientation of $M - B$ as a bundle over S^1 matches the one coming from M . If this orientation of the page Σ matches the orientation as a symplectic manifold, we call a symplectic form ω on Σ *positive*. We shall orient the binding B as the boundary of a page Σ using the outward normal. If, on the other hand, this orientation matches the one coming from a contact form α , i.e. $\alpha \wedge d\alpha^n$, then we say that α induces a *positive contact structure*.

Definition 2.16. A positive contact structure ξ on an oriented manifold M is said to be *carried by an open book* (B, ϑ) if ξ admits a defining contact form α satisfying the following conditions:

- (i) α induces a positive contact structure on B , and
- (ii) $d\alpha$ induces a positive symplectic structure on each fiber of ϑ .

A contact form α satisfying these conditions is said to be *adapted* to (B, ϑ) .

Lemma 2.17. *Suppose that B is a connected contact submanifold of a contact manifold (M, ξ) . A contact form α for (M, ξ) is adapted to an open book (B, ϑ) if and only if the Reeb vector field R_α of α is positively transverse to the fibers of ϑ , i.e. $R_\alpha(\vartheta) > 0$.*

Proof. If $d\alpha$ is positive on each fiber of ϑ , then we can find tangent vectors v_1, \dots, v_{2n} to the fiber Σ at a point x such that $i_{v_1 \wedge \dots \wedge v_{2n}} d\alpha^n > 0$. Hence

$$\iota_{R_\alpha \wedge v_1 \wedge \dots \wedge v_{2n}} \alpha \wedge d\alpha^n > 0.$$

Since the fibers of ϑ and the S^1 direction also orient the manifold, we see that the Reeb vector field is positively transverse to the fibers.

Conversely, if R_α is positively transverse to the fibers of ϑ , then we have $i_{R_\alpha} \alpha \wedge d\alpha^n > 0$, so in particular $d\alpha$ is a positive symplectic form on each fiber.

We assume B to be a contact submanifold, so we only need to check positivity. Note that

$$\int_{\partial\Sigma} \alpha \wedge d\alpha^{n-1} = \int_{\Sigma} d\alpha \wedge d\alpha^{n-1} = \int_{\Sigma} d\alpha^n > 0.$$

Since the binding B was assumed to be connected, we see that (B, ϑ) is a supporting open book. \square

Proposition 2.18. *An abstract contact open book $\text{OB}(\Sigma, \psi)$ admits a natural open book carrying the contact structure ξ in the above construction.*

Proof. We define the binding of the abstract contact open book $M := \text{OB}(\Sigma, \psi)$ to be the submanifold $B := \partial\Sigma \times \{0\}$. The map ϑ from $M - B$ to S^1 can be defined by putting $\vartheta(x) = \varphi$ if $x = (p; r, \varphi)$ is a point in $\partial\Sigma \times D^2$. If x is a point in A , then we put $\vartheta(x) = p(x)$, where $p : A \rightarrow S^1$ is the projection of the fiber bundle, as explained in the beginning of Section 2.15.1. To see that this gives a well-defined map, note that the definitions coincide on the overlap of A and $\partial\Sigma \times D^2$.

The Reeb vector field of the abstract contact open book $\text{OB}(\Sigma, \lambda; \psi)$ as given by the above construction is ∂_φ , so it is positively transverse to all pages. This implies that the open book carries the associated contact structure. \square

Here is a statement for the converse. Its proof will play a role later on.

Proposition 2.19. *Suppose that (B, ϑ) is an open book on M carrying a contact structure ξ . Then there is a Liouville domain $(\bar{\Sigma}, \omega = d\lambda)$ and a symplectomorphism $\psi : \bar{\Sigma} \rightarrow \bar{\Sigma}$ which is the identity near the boundary of $\bar{\Sigma}$ such that $M \cong \text{OB}(\bar{\Sigma}, \psi)$. This symplectomorphism ψ represents the symplectic monodromy, which is well-defined up to symplectic isotopy rel boundary.*

To keep the argument relatively brief, we will cite the following key lemma from [8, Prop. 3.1] and refer to that paper for a proof.

Lemma 2.20 (Giroux [11], Dörner, Geiges and Zehmisch [8]). *Suppose that (M^{2n+1}, ξ) is a compact cooriented contact manifold with supporting open book (B, ϑ) . Assume that α is a contact form defining ξ that is adapted to (B, ϑ) . Then, after an isotopy through adapted contact forms, there is an embedding*

$$j : B \times D^2 \rightarrow \nu_M(B)$$

such that $j|_{B \times \{0\}} = \text{Id}$ and such that

$$j^* \alpha = h_1(r) \alpha_B + h_2(r) d\varphi,$$

where the functions h_1 and h_2 are smooth and satisfy

- (i) $h_2(r) = r^2$ near $r = 0$ and $h_1(r) > 0$;
- (ii) $h_1^{n-1}(h_1 h_2' - h_2 h_1') > 0$ for $r > 0$;
- (iii) $h_1' < 0$ for $r > 0$.

Proof of Proposition 2.19. Choose a smooth increasing function $f : [0, r_0] \rightarrow \mathbb{R}$ such that $f(r) = r$ near $r = 0$ and $f(r) = c$ near $r = r_0$, where $c \in \mathbb{R}_{>0}$ is some constant. The complement of B fibers over the circle with fiber Σ , so we have inclusion maps $j_\varphi : \Sigma \rightarrow \vartheta^{-1}(\varphi)$.

A deformed symplectic structure on the fibers. We claim that the pair $(\Sigma, j_\varphi^* d(1/f(r)^2 \alpha))$ is exact symplectic. Exactness is obvious. For $r \geq r_0$, the function $f(r)$ is constant, so symplecticity follows from condition (ii) of an adapted contact form. For small r we use the key lemma together with the observation that $d(h_1(r)/f(r)^2 \alpha_B)$ restricts to a symplectic form on a page if $h_1(r)/f(r)^2$ is strictly decreasing. The latter claim follows from a computation.

A symplectic connection. The modified symplectic form is motivated by the symplectic monodromy, for which we need to guarantee standard behavior near the binding B . With this modified form in place, we define a symplectic connection by the following rule:

- The vertical bundle Vert is given by the tangent spaces to the fiber.
- The horizontal bundle Hor is given by

$$\text{Hor} = \left\{ v \in T(M - B) \mid i_v d\left(\frac{1}{f(r)^2} \alpha\right) = 0 \right\}.$$

We consider the loop $t \mapsto e^{it} \subset S^1$ and lift its tangent vector field using this symplectic connection. This gives us a horizontal vector field X_h . Before considering its flow, we note that the key lemma tells us that $h_2(r) = r^2$ near $r = 0$, which implies that $X_h = \partial/\partial\varphi$ near the binding B . Hence, the 2π -flow $\psi := \text{Fl}_{2\pi}^{X_h}$ is defined and equal to the identity near the binding.

Furthermore, the Cartan formula tells us that $d(1/f^2 \alpha)$ is preserved under the flow of X_h ,

$$\frac{d}{dt} \text{Fl}_t^{X_h} * d\left(\frac{1}{f^2} \alpha\right) = \text{Fl}_t^{X_h} * \mathcal{L}_{X_h} d\left(\frac{1}{f^2} \alpha\right) = 0,$$

since X_h is horizontal. We conclude that ψ defines a symplectomorphism of the exact symplectic manifold $(\Sigma, j_\varphi^* d(1/f^2 \alpha))$, which is compactly supported.

The fiber Σ is Liouville. We still need to show that Σ is a complete Liouville manifold, meaning that the Liouville flow exists for all time, and that the symplectic monodromy is well-defined up to a compactly supported symplectic isotopy. For the first statement, we define a Liouville vector field X by the equation

$$i_X j^* d\left(\frac{1}{f(r)^2}\alpha\right) = j^*\left(\frac{1}{f(r)^2}\alpha\right).$$

For $0 < r \leq r_0$ we obtain the following explicit formula:

$$X = \frac{f(r)^2 h_1(r)}{h_1'(r) f(r)^2 - 2f(r) f'(r) h_1(r)} \frac{\partial}{\partial r} = -\frac{r}{2}(1 + o(1)) \frac{\partial}{\partial r}.$$

We see that $dr(X) < 0$ for $0 < r \leq r_0$, so this Liouville vector field is outward pointing at each subdomain

$$\Sigma_{r_1} = \{x \in \Sigma \mid r(x) \geq r_1\}.$$

Hence Σ_{r_1} is a Liouville domain filling $(B, \xi = \ker \alpha_B)$. From the expansion near $r = 0$, we see that the flow of X exists for all time, and hence Σ is symplectomorphic to the completion of Σ_{r_1} . This implies that the symplectomorphism type of Σ does not depend on the choices made in the construction.

The symplectic monodromy is well-defined. Finally, different horizontal lifts X_h corresponding to different choices of h_1, h_2 and f give rise to symplectomorphisms that are symplectically isotopic rel boundary. To see this, note that any two choices can be linearly interpolated giving a 1-parameter family of horizontal vector fields $X_{h,s}$. By construction, the vector field $X_{h,s}$ satisfies $X_{h,s} = \partial_\varphi$ near B , so we get a 1-parameter family of symplectomorphisms ψ_s for (Σ, ω_s) that are compactly supported. By Moser stability for Liouville manifolds we find symplectomorphisms $\varphi_s : (\Sigma, \omega_s) \rightarrow (\Sigma, \omega_0)$. The maps $\varphi_s \circ \psi_s \circ \varphi_s^{-1}$ form hence a desired compactly supported symplectic isotopy. \square

2.21. Basic properties of open books.

2.21.1. *Order and monodromy.* In general, the resulting contact manifold depends on the monodromy, but there are some symmetries. For instance, if Σ is a Liouville domain and ψ_1 and ψ_2 are compactly supported symplectomorphisms, then

$$\text{OB}(\Sigma, \psi_2^{-1} \circ \psi_1 \circ \psi_2) \cong \text{OB}(\Sigma, \psi_1).$$

Indeed, we can simply regard the mapping torus of the open book as three products $\Sigma \times I$ glued together, and cyclically change the order of the gluing maps. To see that this yields contactomorphic manifolds, we note that the symplectic isotopy type of the monodromy determines the contact structure; this follows from an application of Gray stability. Finally, the maps ψ_2 and ψ_2^{-1} cancel when glued together in a pair of $\Sigma \times I$'s.

This observation also implies the cyclic symmetry property,

$$\text{OB}(\Sigma, \psi_1 \circ \psi_2) \cong \text{OB}(\Sigma, \psi_2 \circ \psi_1).$$

Indeed, if we conjugate $\psi_2 \circ \psi_1$ by ψ_2 , we get the above expression.

2.22. Important examples of monodromies. In general, the group of symplectomorphisms on a symplectic manifold is poorly understood. In fact, in many cases, such as (D^6, ω_0) , it is even unknown whether every symplectomorphism is isotopic to the identity (relative to the boundary).

There is, however, a way to construct candidates of symplectomorphisms that are in general not isotopic to the identity. Suppose that (W, ω) is a symplectic manifold with an embedded Lagrangian sphere $L \subset W$. By the Weinstein neighborhood theorem, a neighborhood $\nu_W(L)$ is symplectomorphic to the canonical symplectic structure on $(T^*_{<\varepsilon} S^n, d\lambda_{\text{can}})$.

Hence we consider the symplectic manifold $(T^* S^n, d\lambda_{\text{can}})$, where λ_{can} is the canonical 1-form. For later computations, we first regard this manifold as a submanifold of $T^*\mathbb{R}^{n+1} \cong \mathbb{R}^{2n+2}$ by using coordinates

$$(q, p) = (q_1, \dots, q_{n+1}, p_1, \dots, p_{n+1}) \in \mathbb{R}^{2n+2}$$

subject to the relations

$$(1) \quad q \cdot q = \sum_{i=1}^{n+1} q_i^2 = 1 \quad \text{and} \quad q \cdot p = \sum_{i=1}^{n+1} q_i p_i = 0.$$

In these coordinates, the canonical 1-form is given by

$$\lambda_{\text{can}} = j^* p dq = j^* \sum_{i=1}^{n+1} p_i dq_i,$$

where j denotes the inclusion map of $T^* S^n \rightarrow T^*\mathbb{R}^{n+1}$.

Remark 2.23. In later computations we will drop the pullback j^* from the notation, and directly impose the relations (1).

We will now describe a so-called Dehn twist using these coordinates. Define an auxiliary map describing the normalized geodesic flow

$$\sigma_t(q, p) = \begin{pmatrix} \cos t & |p|^{-1} \sin t \\ -|p| \sin t & \cos t \end{pmatrix} \begin{pmatrix} q \\ p \end{pmatrix}.$$

Then define

$$\tau(q, p) = \begin{cases} \sigma_{g_1(|p|)}(q, p) & \text{if } p \neq 0, \\ -\text{Id} & \text{if } p = 0. \end{cases}$$

Here g_1 is a smooth function with the following properties:

- $g_1(0) = \pi$ and $g'_1(0) < 0$.
- Fix $p_0 > 0$. The function $g_1(|p|)$ decreases to 0 at p_0 after which it is identically 0.

Note that the conditions imply that τ is actually a smooth map. See Figure 2. The map τ is called a (*generalized*) *right-handed Dehn twist*.

Since τ is the identity near the boundary of $T^*_{<\varepsilon} S^n$, we can extend τ to a symplectomorphism of (W, ω) : simply extend τ to be the identity outside the support of τ .

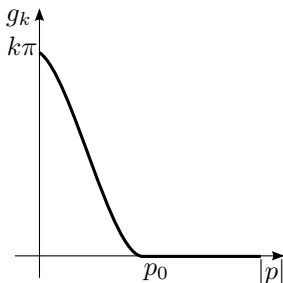

FIGURE 2. The amount of geodesic flow for a k -fold Dehn twist.

Remark 2.24. Dehn twists are of course very old, but the symplectic incarnation of such a twist was only more recently observed by Arnold [2] who noted that one can define a *symplectic* monodromy around a quadratic singularity. Seidel’s results on Dehn twists, see [21, 22, 23] for some of them, gave symplectic Dehn twists a prominent role in symplectic topology; for example, he showed that Dehn twists have infinite order in the compactly supported symplectic mapping class group of T^*S^n . This is remarkable, since the compactly supported smooth mapping class group of T^*S^n has finite order for n even. Giroux’ results in [11] clarified the role of Dehn twists in contact topology. In higher-dimensional contact topology, various aspects of Dehn twists were worked out in for example [1, 24, 3].

3. CONTACT SURGERY AND SYMPLECTIC HANDLE ATTACHMENT

Let (M^{2n+1}, ξ) be a contact manifold, and let S in M be an isotropic k -sphere with a trivialization ϵ of its conformal symplectic normal bundle. Then we can perform contact surgery along (S, ϵ) . We shall write the surgered contact manifold as

$$\widetilde{(M, \xi)}_{S, \epsilon}.$$

In the case of Legendrian surgery or in case of connected sums ($k = 0$), there is no choice for the framing ϵ , and consequently, we shall drop the framing from the notation in these cases.

We shall now describe a model for contact surgery in terms of symplectic handle attachment. For later computations, we slightly modify Weinstein’s original construction [25].

3.1. “Flat” Weinstein model for contact surgery. Here we shall discuss a slightly modified version of the Weinstein model for contact surgery. Let $(M, \xi = \ker \alpha)$ be a contact manifold and suppose that S is an isotropic k -sphere in (M, ξ) with trivial conformal symplectic normal bundle, trivialized by ϵ . Using this framing ϵ and a neighborhood theorem, see [9, Thm. 6.2.2],

we can find a *strict* contact embedding

$$\psi : (\nu(S), \alpha) \rightarrow \left(\mathbb{R} \times T^*S^k \times \mathbb{R}^{2(n-k)}, dz + pdq + \frac{1}{2}(x dy - y dx) \right),$$

where we regard $\mathbb{R} \times T^*S^k \times \mathbb{R}^{2(n-k)}$ as a neighborhood of $\{0\} \times S^k \times \{0\}$.

Remark 3.2. We should point out that the contactomorphism ψ depends on the trivialization ϵ . As a result, the entire construction we shall now describe depends on this choice. Note that this is unavoidable, since even smoothly the result of surgery depends on the choice of framing.

A priori, we can only expect a small neighborhood of S to be contactomorphic to a *small* subset of $\mathbb{R} \times T^*S^k \times \mathbb{R}^{2(n-k)}$ via a strict contactomorphism, but we can enlarge this neighborhood by composing with the following non-strict contactomorphism

$$\begin{aligned} \varphi_C : \mathbb{R} \times T^*S^k \times \mathbb{R}^{2(n-k)} &\rightarrow \mathbb{R} \times T^*S^k \times \mathbb{R}^{2(n-k)}, \\ (z, q, p; x, y) &\mapsto (Cz, q, Cp; \sqrt{C}x, \sqrt{C}y). \end{aligned}$$

Now consider the following model for contact surgery and symplectic handle attachment. Consider the symplectic manifold $(\mathbb{R}^{2n+2}, \omega_0)$. We shall use coordinates $(x, y; z, w)$, where there are $n - k$ pairs of (x, y) coordinates and $k + 1$ pairs of (z, w) coordinates. The symplectic form is then given by

$$\omega_0 = dx \wedge dy + dz \wedge dw.$$

Note that the vector field

$$X = \frac{1}{2}(x\partial_x + y\partial_y) + 2z\partial_z - w\partial_w$$

is Liouville for ω_0 .

Now consider the set

$$S_{-1} := \{(x, y, z, w) \in \mathbb{R}^{2n+2} \mid |w|^2 = 1\}.$$

The Liouville vector field X is transverse to this set, and induces the contact form

$$\alpha = \frac{1}{2}(x dy - y dx) + 2z dw + w dz.$$

We see that the sphere

$$\{(x, y, z, w) \mid x = y = 0, z = 0, |w|^2 = 1\} \cong S^k$$

describes an isotropic sphere in S_{-1} with trivial conformal symplectic normal bundle. We shall think of S_{-1} as a neighborhood of the isotropic sphere S , in other words S_{-1} can be thought of as the situation before surgery. In fact, the set S_{-1} is a standard neighborhood of an isotropic sphere of dimension k with trivial normal bundle, since we have the following contactomorphism:

$$\begin{aligned} (2) \quad \psi_W : \mathbb{R} \times T^*S^k \times \mathbb{R}^{2(n-k)} &\rightarrow S_{-1}, \\ (z, q, p, x, y) &\mapsto (x, y; zq + p, q). \end{aligned}$$

Here we regard the cotangent bundle T^*S^k as a subspace of $\mathbb{R}^{2(k+1)}$ by using coordinates $(q, p) \in \mathbb{R}^{2(k+1)}$, where $q^2 = 1$ and $q \cdot p = 0$. Note that ψ_W is a strict contactomorphism,

$$\begin{aligned} \psi_W^* \left(\frac{1}{2}(x dy - y dx) + 2z dw + w dz \right) \\ &= \frac{1}{2}(x dy - y dx) + 2(zq + p)dq + q d(zq) + q dp \\ &= \frac{1}{2}(x dy - y dx) + p dq + dz. \end{aligned}$$

To see that the latter step holds, use that $q dq = 0$ and $p dq + q dp = 0$.

We can combine the above three maps to obtain a contactomorphism from $\nu(S) \subset M$ to S_{-1} in the Weinstein model

$$(3) \quad \Phi_C := \psi_W \circ \varphi_C \circ \psi : \nu(S) \rightarrow S_{-1}.$$

This map is not a strict contactomorphism, but since it multiplies the contact form with a constant rather than an arbitrary function, we can adapt the following lemma from [9, Lem. 5.2.4] for a gluing construction.

Lemma 3.3. *For $i = 0, 1$, let (M_i, α_i) be a (not necessarily closed) contact type hypersurface in a symplectic manifold (W_i, ω_i) with respect to the Liouville vector field Y_i . Suppose $\varphi : (M_0, \alpha_0) \rightarrow (M_1, \alpha_1)$ is a contactomorphism such that $\varphi^* \alpha_1 = C \alpha_0$ for some constant C . Then φ extends to a symplectomorphism between neighborhoods of M_0 and M_1 by sending flow lines of Y_0 to flow lines of Y_1 .*

Furthermore, we can choose a large C in formula (3), which means that we can get arbitrary large neighborhoods in the Weinstein model.

Remark 3.4. We can also adapt the proof of [4, Prop. 3.1] to obtain a contactomorphism from $\nu(S)$ to the full Weinstein model, i.e. a surjective map to S_{-1} . As can be seen for volume reasons, this contactomorphism is in general not strict or suitable for Lemma 3.3. Therefore, we shall restrict ourselves to a contactomorphism as in formula (3).

3.4.1. *Attaching a symplectic handle.* Let us begin by defining a symplectic handle. The contactomorphism Φ_C identifies the neighborhood $\nu(S) \subset M$ with a neighborhood of the isotropic sphere in S_{-1} . Suppose that the neighborhood provided by ψ has size

$$\text{size}_\psi(\nu(S)) := \max_{(x,y,z,w) \in \psi(\nu(S))} \sqrt{x^2 + y^2 + z^2} = \tilde{\varepsilon}.$$

Then by choosing $C > 2/\tilde{\varepsilon}$, we can ensure that the neighborhood provided by Φ_C has size larger than 1, i.e. the maximal (x, y, z) coordinates are larger than 1.

We first define the profile for the handle. Fix a small $\delta > 0$: this parameter serves as a smoothing parameter. Choose smooth functions $f, g : \mathbb{R}_{\geq 0} \rightarrow \mathbb{R}$ such that

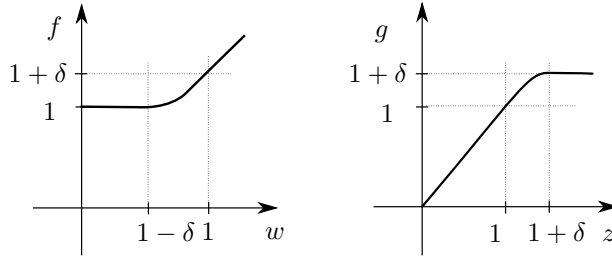

FIGURE 3. Functions for the profile of a symplectic handle.

- f is increasing on $]1 - \delta, \infty[$;
- $f(w) = 1$ for $w \in [0, 1 - \delta]$, $f(w) = w + \delta$ for $w > 1 - \delta/2$;
- g is increasing on $]0, 1 + \delta[$;
- $g(z) = z$ for $z < 1$, $g(w) = 1 + \delta$ for $w > 1 + \delta$.

See Figure 3 for a sketch of these functions.

Define

$$F(x, y, z, w) := -f(w^2) + g(x^2 + y^2 + z^2).$$

Define a hypersurface $S_1 := \{(x, y, z, w) \mid F(x, y, z, w) = 0\}$. This hypersurface is of contact type, because the Liouville vector field X is transverse to S_1 . Indeed,

$$X(F) = \left(\frac{1}{2}(x^2 + y^2) + 2z^2\right)g' + w^2f' > 0$$

for points x, y, z, w such that $F(x, y, z, w) = 0$, as points with $g' = 0$ are precisely those with $w^2 = 1$, and points with $f' = 0$ are those with $x^2 + y^2 + z^2 = 1$. The hypersurface S_1 is meant to describe the result of the surgery along S . See Figure 4 for a sketch of the situation.

Remark 3.5. Instead of a profile for a symplectic handle described by the above function F , one more commonly chooses a profile of the form

$$x^2 + y^2 + z^2 - w^2 = c.$$

The advantage is that

$$G = x^2 + y^2 + z^2 - w^2$$

defines an ω -convex Morse function with respect to the Liouville vector field X with one critical point on the handle. The main reason for preferring F is that it simplifies later computations. Note that topologically the two profiles are the same. Furthermore, one can adapt the ω -convex function G to the above profile as well. See the summary in Proposition 3.8.

In order to describe the surgery we shall use handle attachment along a symplectic manifold (W, ω) with contact type boundary M . Define the symplectic handle (H_{k+1}, ω_0) as follows: the handle H_{k+1} consists of those points $p \in (\mathbb{R}^{2n+2}, \omega_0)$ such that one of the following three conditions holds:

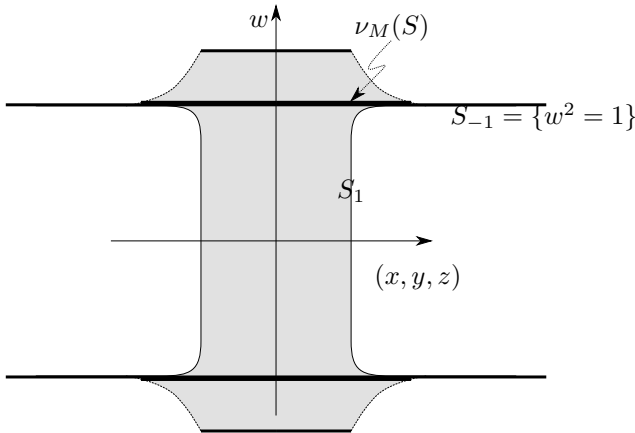

FIGURE 4. A symplectic handle in the flat Weinstein model.

- There is a $t \in [0, 1]$ such that the time- t flow of X satisfies $Fl_t^X(p) \in \Phi_C(\nu(S))$. This is the gluing part of the symplectic handle.
- There are $t_1 \leq 0$ such that $Fl_{t_1}^X(p) \in \Phi_C(\nu(S))$ and $t_2 \geq 0$ such that $Fl_{t_2}^X(p) \in S_1$.
- p is the unique critical point of X , namely 0 .

This set is illustrated in the gray region of Figure 4.

Let us now attach this symplectic handle H_{k+1} to (W, ω) . A neighborhood of the boundary of (W, ω) is symplectomorphic to $([-1, 0] \times M, d(e^t \alpha))$; call this symplectomorphism $\psi_\partial : \nu_W(M) \rightarrow [-1, 0] \times M$ (note that we can attach a piece of a symplectization of M to W to ensure we have such a neighborhood). In particular, we have a symplectomorphism

$$\psi_\partial : \nu_W(\nu_M(S)) \rightarrow [-1, 0] \times \nu_M(S).$$

We can compose this symplectomorphism with the map

$$\tilde{\Phi}_C : [-1, 0] \times \nu_M(S) \rightarrow H_{k+1}, \quad (t, p) \mapsto Fl_t^X(\Phi_C(p)).$$

This map is also a symplectomorphism, cp. Lemma 3.3 (or rescale the symplectic form on H_{k+1}).

Now attach the symplectic handle

$$\tilde{W} := W \cup H_{k+1} / \sim .$$

Here we glue x in $\nu_W(\nu_M(S)) \subset W$ to y in H_{k+1} if and only if $\tilde{\Phi}_C \circ \psi_\partial(x) = y$. By Lemma 3.3 the resulting manifold \tilde{W} is again symplectic and its boundary is a contact manifold that is diffeomorphic to the surgered manifold $(M, \xi)_{S, \epsilon}$, obtained by performing surgery on M along the isotropic submanifold S with framing ϵ .

Definition 3.6. The above attaching procedure is called *symplectic handle attachment* along S at the convex end of W^{2n+2} , which is a $2n + 1$ -dimensional

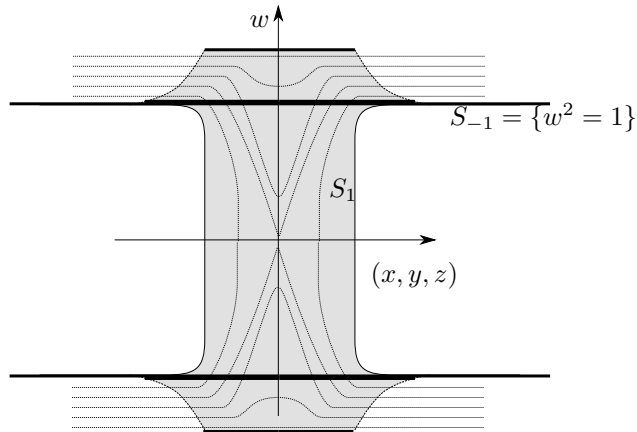

FIGURE 5. A sketch of the modifications to glue ω -convex functions.

contact manifold. We call the attachment *subcritical* if $\dim S < n$, and *critical* if $\dim S = n$. The induced operation on the convex end is called *contact surgery* along S . The contact surgery is called *subcritical* if $\dim S < n$, and *critical* or *Legendrian* if $\dim S = n$.

Remark 3.7. Since we attach a symplectic handle to a cobordism by gluing flow lines of the respective Liouville vector fields, we see that we can extend the Liouville vector field defined in a neighborhood of the convex end of W to the new symplectic manifold $(\widetilde{W}, \tilde{\omega})$.

As alluded to in Remark 3.5, there is a function on a symplectic handle that is ω_0 -convex for the Liouville vector field X . By slightly modifying the ω -convex function f on W , we can glue this function to the one on the symplectic handle. This is sketched in Figure 5.

Let us summarize the above discussion in the following proposition.

Proposition 3.8. *Let (W, ω) be a symplectic cobordism. Suppose that $i : S \rightarrow \partial W$ is an embedded isotropic k -sphere in the convex end of W whose conformal symplectic normal bundle is trivialized by ϵ .*

Then we can attach a handle H_{k+1} to W along S with framing ϵ to obtain a symplectic cobordism $(\widetilde{W}, \tilde{\omega})$. Furthermore, if (W, ω) admits an ω -convex function f , then f can be extended to an $\tilde{\omega}$ -convex function \tilde{f} on \widetilde{W} such that \tilde{f} has only one additional critical point.

Remark 3.9. We see that we can attach symplectic handles under rather mild assumptions to the convex end of a symplectic manifold. The converse, i.e. attaching handles to the concave end of a symplectic manifold, is much more restrictive. Indeed, there are many examples of non-fillable contact manifolds, which illustrates that concave handle attachment has additional requirements.

3.10. Symplectic handle cancellation. The main technical tool we shall use is Eliashberg's symplectic cancellation theorem. A good reference is [6, Prop. 12.22]. Here is a formulation that is suitable for our purposes.

Lemma 3.11 (Cancellation theorem). *Let (W, ω) be a symplectic manifold and f be an ω -convex function. Let p and q be non-degenerate critical points of f and $d \in]f(p), f(q)[$. Suppose the following:*

- $\text{index}_q(f) = \text{index}_p(f) + 1$.
- *The sphere S_q^- , obtained by intersecting the stable manifold $W^s(q)$ with the level set $\{x \mid f(x) = d\}$, intersects the sphere S_p^+ , formed by intersecting the unstable manifold $W^u(p)$ with $\{x \mid f(x) = d\}$, transversely in one point.*

Then the critical points can be cancelled by a J -convex deformation of f in a neighborhood of $[f(p), f(q)]$.

Given the lemma, we can perform symplectic handle cancellation in a way similar to the one in the smooth case, see [17, Thm. 5.6]. We shall briefly describe the particular set-up which we shall use. This will be the simplest case of handle cancellation: it can occur after consecutive attachment of handles with index difference 1.

Let (W_1^{2n}, ω) be a symplectic manifold such that $M_1 \subset \partial W_1$ is a convex end. Choose an ω -convex function f_1 near the convex end and let X_1 be the associated Liouville vector field.

Remark 3.12. The reader may be confused by our change in conventions for the dimensions. The reason shall become clear in the next section. We are interested in a $2n + 1$ -dimensional contact manifold M which has an open book whose binding is $2n - 1$ -dimensional; the page of this open book is a $2n$ -dimensional symplectic manifold. However, we also have cobordisms involving M , and these involve $2n + 2$ -dimensional symplectic manifolds. Since all the pieces interact with each other, this clash of dimensions is unavoidable.

Now suppose that $\Sigma_1 \subset M_1^{2n-1}$ is an isotropic $(n - 2)$ -sphere with a trivialization ϵ of its conformal symplectic normal bundle. Suppose furthermore that Σ_1 bounds a Legendrian $(n - 1)$ -disk D_1 in M_1 . Now form the symplectic manifold (W_2, ω_2) by attaching a symplectic $(n - 1)$ -handle along Σ_1 ,

$$(W_2, \omega_2) = W_1 \cup_{\Sigma_1, \epsilon} H_{n-1}.$$

The ω_1 -convex function f_1 can be extended to an ω_2 -convex function f_2 as mentioned in Remark 3.7: this new ω_2 -convex function has one additional critical point, corresponding to the middle of the handle. We shall denote this critical point by p .

Note that the convex end M_1 is surgered into a new convex end $M_2 \subset \partial W_2$. This convex end comes with a Legendrian $(n - 1)$ -sphere Σ_2 which is formed as follows.

First observe that there is a parallel copy D_2 of the core of H_{n-1} which is a Legendrian $(n - 1)$ -disk. More explicitly, by using the flat Weinstein model,

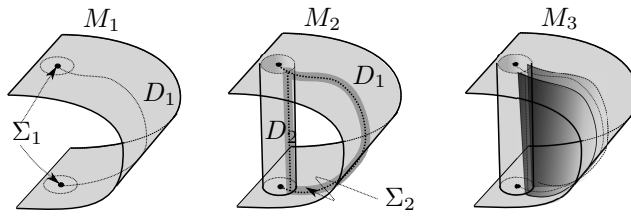

FIGURE 6. The sequence of surgeries.

we put

$$\varphi : D^{n-1} \rightarrow H_{n-1}, \quad w \mapsto (x_0; 0, w).$$

Here $x_0 = (1, 0) \in D^2$. We see directly that $\alpha = 1/2(x dy - y dx) + 2z dw + w dz$ restricts to 0 on $D_2 := \varphi(D^{n-1})$. After smoothing, we can glue D_1 (which is partially removed after the handle attachment of H_{n-1}) to D_2 . This gives the Legendrian sphere Σ_2 . The surgery spheres and the surgeries are illustrated in Figure 6

Remark 3.13. To visualize the handle cancellation that is going to occur in the next step, observe that Σ_2 intersects the belt sphere of H_{n-1} transversely in one point, namely in $\varphi(0)$.

Since Σ_2 is Legendrian, the conformal symplectic normal bundle is trivial (it has rank 0), so we can form W_3 by critical n -handle attachment along Σ_2 without reference to a framing,

$$(W_3, \omega_3) := W_2 \cup_{\Sigma_2} H_n.$$

As before, we can extend the ω_2 -convex function f_2 to an ω_3 -convex function f_3 on W_3 . Denote the additional critical point of f_3 by q . We shall denote the gradient-like Liouville vector field on W_3 by X_3 . The convex end M_2 is surgered yielding the contact manifold M_3 .

Now intersect a level set $\{f_3 = d\}$, with d between $f_3(p)$ and $f_3(q)$, with the stable manifold $W^s(q)$ and the unstable manifold $W^u(p)$ to form the spheres $S^-(q)$ and $S^+(p)$, respectively. These spheres intersect transversely in one point, as we can see from the unique flow line of the Liouville vector field X_3 from p to q . This is illustrated in Figure 7.

This means that Lemma 3.11 applies, so we can deform f_3 to another ω_3 -convex function g_3 such that $g_3(x) = f_3(x)$ on sublevel sets $\{f_3 < c = f_1(p) - \delta\}$. In particular, on such sublevel sets g_3 coincides with f_1 . Furthermore, the function g_3 has no critical points whenever $g_3(x) \geq c$. This means that $\{g_3(x) \geq c\}$ looks like a symplectization, so we conclude that the completion of W_1 , i.e. the manifold obtained from W_1 by attaching the positive end of a symplectization, is symplectomorphic to the completion of W_3 .

We summarize the conclusion in the following lemma.

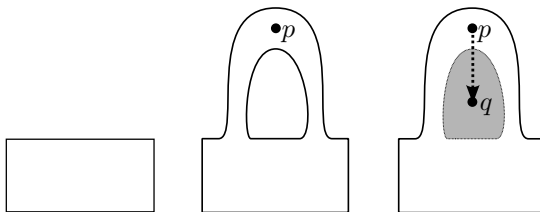

FIGURE 7. Cancellation of symplectic handles: the creation of a unique flow line between the critical points q and p .

Lemma 3.14 (Handle cancellation in successive handle attachment). *Let (W_1, ω_1) and (W_3, ω_3) be the symplectic manifolds as formed above by successive handle attachment. Then the completion of (W_1, ω_1) is symplectomorphic to the completion of (W_3, ω_3) . In particular, M_1 is contactomorphic to M_3 .*

4. SURGERY AND OPEN BOOKS

In this section we try to describe some relations between contact surgery and open books. Let us summarize the results that will be proved below. If an isotropic sphere S lies in the binding of an open book and if the framing is compatible with the open book, then subcritical surgery along S can also be described in terms of handle attachment to the pages of an open book.

On the other hand, critical contact surgery can be regarded as a change in the monodromy of the open book, if the sphere used for the surgery lies nicely in a page.

We apply this to show that stabilization of open books leads to contactomorphic contact manifolds. The basic strategy is the following. To stabilize an open book we attach an n -handle to the $2n$ -dimensional page forming a new Lagrangian sphere and change the monodromy by composing with a right-handed Dehn twist along the newly formed Lagrangian sphere.

We shall show that the handle attachment to the page can be realized by a subcritical handle attachment to the convex end of $[-1, 0] \times M$ and that the change in monodromy is realized by a critical handle attachment. The latter turns out to cancel the former, so we obtain the same contact manifold.

4.1. Subcritical surgery and open books. Let us first describe the situation for trivial monodromy, since that situation is more easily visualizable. Let Σ be a Weinstein domain with boundary $B := \partial\Sigma$ and consider the open book

$$M := \text{OB}(\Sigma, \text{Id}).$$

Suppose that S is an isotropic (possibly Legendrian) sphere in B with a trivialization ϵ of its conformal symplectic normal bundle. We can perform contact surgery along (S, ϵ) giving rise to a contact manifold \tilde{B} . The associated surgery cobordism also gives a Weinstein (and hence Stein) filling for \tilde{B} , which we will

denote by $\widetilde{\Sigma}$. Alternatively, $\widetilde{\Sigma}$ can be regarded as the Weinstein domain obtained from Σ by handle attachment along (S, ϵ) .

Note that S also gives rise to an isotropic submanifold of M . Indeed, we have an isotropic sphere in the binding: take $S_M := S \times \{0\} \subset B \times D^2$. Since we have the following contact form near the binding,

$$\lambda + x dy - y dx,$$

we see that we also get a trivialization of the conformal symplectic normal bundle of $S_M \subset M$, given by $\epsilon_M := \epsilon \oplus \langle \partial_x, \partial_y \rangle$. For later use, it is useful to give the last factor a name,

$$\epsilon_{D^2} = \langle \partial_x, \partial_y \rangle.$$

Contact surgery on M along (S_M, ϵ_M) gives the subcritically fillable contact manifold $\widetilde{M} := \partial(\widetilde{\Sigma} \times D^2)$, as we can see from performing handle attachment to the filling $\Sigma \times D^2$ of M . On the level of open books, we see that \widetilde{M} has a supporting open book with page $\widetilde{\Sigma}$ and the identity as monodromy.

This set-up also describes the general situation, since the surgery takes place near the binding. As a result, we have the following proposition.

Proposition 4.2. *Let Σ be a Liouville domain with boundary B and let ψ be a compactly supported symplectomorphism such that*

$$M := \text{OB}(\Sigma, \psi)$$

is a contact open book. Suppose that S_B is an isotropic $(k - 1)$ -sphere in the binding B with a trivialization ϵ of its conformal symplectic normal bundle in B . Then there is a corresponding isotropic $(k - 1)$ -sphere $S_M \subset M$ with trivialization $\epsilon \oplus \epsilon_{D^2}$ of its conformal symplectic normal bundle such that

$$\text{OB}(\Sigma \cup_{S_B, \epsilon} H_k, \psi \cup_{S_B} \text{Id}) \cong \widetilde{\text{OB}}(\Sigma, \psi)_{(S_M, \epsilon \oplus \epsilon_{D^2})}.$$

In other words, this kind of subcritical surgery is realized by handle attachment to the page of an open book without changing the monodromy.

4.3. Critical surgery and open books. Now consider a contact open book $M := \text{OB}(\Sigma, \psi)$ having a Lagrangian sphere L_S in a page. We show that we can assume that L_S represents a Legendrian sphere in $\Sigma \times \mathbb{R}$, or in other words in the contact open book M .

Lemma 4.4. *Let $M^{2n+1} = \text{OB}(\Sigma, \psi)$ be a contact manifold of dimension greater than 3. If L_S is a Lagrangian sphere in the page of a contact open book M^{2n+1} , then we can isotope the contact structure on M^{2n+1} and find a supporting open book with symplectomorphic page and isotopic monodromy such that L_S becomes Legendrian in M^{2n+1} .*

Proof. Suppose λ is a primitive of the symplectic form ω on $\widetilde{\Sigma}$. Then on a Weinstein neighborhood of L_S we can find a primitive

$$\lambda_{\text{can}} = p dq$$

of the symplectic form ω , where (q, p) are coordinates on $T_{\leq \varepsilon}^* S^n \cong \nu(L_S)$. Since $\lambda - \lambda_{\text{can}}$ is closed, we can find a function g such that

$$\lambda - \lambda_{\text{can}} = dg,$$

because $H_{dR}^1(S^n) = 0$ as $n > 1$. Now put

$$\tilde{\lambda} := \lambda - d(\rho g),$$

where ρ is a smooth cut-off function that is 1 in a neighborhood of L_S with support in the Weinstein neighborhood $\nu(L_S)$. Note that $d\tilde{\lambda} = d\lambda$ is still symplectic.

On the Lagrangian sphere L_S , $\tilde{\lambda}$ vanishes, so L_S lies in the kernel of the contact form $dt + \tilde{\lambda}$, so it is Legendrian. Furthermore, the associated contact structure is isotopic to the one we started with by Gray stability. \square

Remark 4.5. In dimension 3, every curve in a page is Lagrangian, but to realize a curve as a Legendrian one needs to perturb transversely to a page. Hence we cannot directly formulate an analog to Lemma 4.4. On the other hand, in dimension 3 one can always find a supporting open book such that a Legendrian lies in a page, see [10, §4] for a discussion of the 3-dimensional situation.

Given the Lagrangian sphere L_S , we get a compactly supported symplectomorphism τ_{L_S} , a right-handed Dehn twist along L_S . We can now change the monodromy of the contact open book by adding Dehn twists along L_S , but we can also perform critical contact surgery along L_S : we will refer to this as Legendrian surgery. We shall now show that these operations coincide.

4.5.1. *Surgery and monodromy.* The goal of this section is to provide a proof of the following folk theorem. This result is well known in dimension 3, see [10].

Theorem 4.6. *Let $\text{OB}(\Sigma, \psi)$ be a contact open book with Legendrian sphere L_S , that restricts to a Lagrangian sphere in Σ . Denote the contact manifold obtained from $\text{OB}(\Sigma, \psi)$ by Legendrian surgery along L_S by $\text{OB}(\widetilde{\Sigma}, \psi)_{L_S}$. Then the contact manifolds*

$$\text{OB}(\Sigma, \psi \circ \tau_{L_S}) \cong \widetilde{\text{OB}(\Sigma, \psi)}_{L_S}$$

are contactomorphic.

Proof. The proof has two steps. In the first step we shall show that Legendrian surgery on $\text{OB}(\Sigma, \psi)$ along L_S yields a contact manifold with a supporting open book $(B, \tilde{\vartheta}_r)$, where B is the binding and $\tilde{\vartheta}_r$ the map to S^1 . The new supporting open book has the same page as the supporting open book before the surgery, and we can localize the monodromy. In the second step we determine how the monodromy is changed.

Step 1: Supporting open book after surgery. A schematic of the setup is sketched in Figure 8. The contact open book $\text{OB}(\Sigma, \psi)$ gives rise to a contact

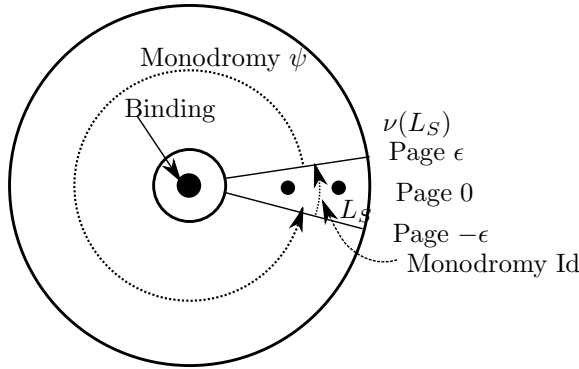

FIGURE 8. Pages around a Legendrian sphere.

manifold (M, ξ) with a supporting open book (B, ϑ) , where B is a codimension-2 submanifold of M and $\vartheta : M - B \rightarrow S^1$ a fiber bundle over S^1 . We think of L_S as a Legendrian submanifold of (M, ξ) lying in the page $[0] \in \mathbb{R}/\mathbb{Z} \cong S^1$. Choose a neighborhood $\nu(L_S)$ of L_S such that $\nu(L_S)$ is contactomorphic to a neighborhood of the zero section in $\mathbb{R} \times T^*L_S$, and such that $\nu(L_S) \subset \vartheta^{-1}(]-\varepsilon, \varepsilon[)$. In particular, we can restrict the map ϑ to a map

$$\vartheta_r := \vartheta|_{\nu(L_S)} : \nu(L_S) \rightarrow]-\varepsilon, \varepsilon[.$$

Note that $\nu(L_S)$ can be identified with a neighborhood of $\{z = 0\}$ in the hypersurface of contact type $\{w^2 = 1\} \subset \mathbb{C}^n$, as described before in the interlude on the “flat” Weinstein model. Let us use the identification from Section 3.1 to choose a specific model for ϑ_r .

By isotoping the open book and applying Gray stability, we can assume that the restricted map ϑ_r has the form

$$\vartheta_r : \nu(L_S) \rightarrow]-\varepsilon, \varepsilon[, \quad (z, w) \mapsto z \cdot w.$$

Indeed, since the Reeb vector field on $\{w^2 = 1\}$ is given by

$$R_B = w\partial_z,$$

we see that $R(\vartheta_r) > 0$, so ϑ_r gives also a supporting open book for (M, ξ) by Lemma 2.17.

Next perform Legendrian surgery along L_S using the “flat” Weinstein model as described in Section 3.1. This means that we remove a neighborhood $\nu_{M, \delta'}(L_S)$ of L_S and glue in the set S_1 , which is the zero set of the function $F(z; w) = -f(w^2) + g(z^2)$. We claim that we still have an open book structure after surgery, and that the topology of the page is unchanged.

We start by checking the former claim. In our set-up, the Reeb vector field on S_1 is a positive multiple of the Hamiltonian vector field of F , which is given by

$$X_F = \frac{\partial F}{\partial z} \partial_w - \frac{\partial F}{\partial w} \partial_z = 2g'z\partial_w + 2f'w\partial_z.$$

By our choice of the functions f and g we see that

$$R(z \cdot w) = NX_F(z \cdot w) = N(2g'|z|^2 + 2f'|w|^2) > 0,$$

so the function ϑ_r , now defined on S_1 rather than $\nu(L_S)$, also defines a suitable open book projection on S_1 . Moreover, the map ϑ_r extends to a smooth submersion $\tilde{\vartheta} : \widetilde{M} - B \rightarrow S^1$. To see this, we note that it coincides near the pages $\pm\epsilon$ with the original map ϑ . Indeed, at the fiber $\tilde{\vartheta}^{-1}(\pm\epsilon)$ we have $|z| \geq \epsilon$, and the set $S_1 \cap |z| \geq \epsilon$ equals the set $S_{-1} \cap |z| \geq \epsilon$ as we see from the construction in Section 3.4.1 and Figure 5. The computations below make this more explicit.

In particular, $\tilde{\vartheta}$ defines a fiber bundle over the circle. Its fibers are all diffeomorphic, and as $\tilde{\vartheta}$ coincides with ϑ away from the surgery locus, say for example for $\vartheta^{-1}(\epsilon) \subset M - \nu(L_S) = \widetilde{M} - S_1$, we conclude that the fibers of ϑ and $\tilde{\vartheta}$ are diffeomorphic.

Step 2: Monodromy. Let us now investigate the symplectic monodromy as described in the proof of Proposition 2.19. We make first two observations. First of all, the Legendrian surgery takes place away from the binding. Hence we can choose a symplectic connection such that the horizontal lift X_h of the tangent vector field to the loop $t \mapsto e^{it}$ is a multiple of the Reeb vector field R_α on the surgery locus. Secondly, the change of the monodromy can be localized in an ϵ -neighborhood of page 0, and furthermore this change of monodromy does not depend on the choice of L_S , since we have described the entire set-up with the Weinstein model. So we see that

$$\text{OB}(\widetilde{\Sigma}, \psi)_{L_S} \cong \text{OB}(\Sigma, \psi \circ \psi_{L_S}),$$

where ψ_{L_S} is the change in monodromy. Hence we only need to see what Legendrian surgery does to the monodromy in a single model situation to determine ψ_{L_S} .

Monodromy before surgery. Let us first compute the monodromy from page $-\epsilon$ to page ϵ before the surgery. We start by taking a point in the page $-\epsilon$ near the surgery region, say $(-\epsilon; q, p) \in [-\epsilon, \epsilon] \times T^*S^n$. Map this point with ψ_W , defined in equation (2), to S_{-1} , the flat Weinstein model before surgery. We find

$$\psi_W(-\epsilon, q, p) = (-\epsilon q + p, q).$$

The set S_{-1} is described by the level set of the Hamiltonian $w^2 = 1$. The time s -flow of this Hamiltonian, which is a positive reparametrization of the Reeb flow, sends

$$(-\epsilon q + p, q) \mapsto ((2s - \epsilon)q + p, q).$$

Applying ψ_W^{-1} , we find $(2s - \epsilon, q, p)$. To reach page ϵ , we need to choose $s = \epsilon$, resulting in the map

$$(-\epsilon, q, p) \mapsto (\epsilon, q, p),$$

which is the identity on the T^*S^n -factor. Note that this map serves as a reference identification for the monodromy after surgery, which we will compute now.

Monodromy after surgery. Let us now consider the monodromy after surgery. As before take $(-\varepsilon, q, p) \in \{-\varepsilon\} \times T^*S^n$. Applying the map ψ_W , we get $(z, w) = (-\varepsilon q + p, q) \in S_{-1}$. We note that on page $\pm\varepsilon$, we have $|z| \geq \varepsilon$, which is needed to perform surgery. To go to the surgered set S_1 , we use the flow of the Liouville vector fields

$$X_a := (1 + a)z\partial_z - aw\partial_w.$$

For each a , this gives a map $\psi_a : S_{-1} - \{z = 0\} \rightarrow S_1$. We will first identify a subset of S_{-1} with the flat parts of S_1 , i.e. those subsets of S_1 , where either f' or g' is zero. This allows us to explicitly compute ψ_a . The time- t flow of X_a sends

$$(z, w) \mapsto (e^{(1+a)t}z, e^{-at}w),$$

so for those points mapping to the flat piece $\{p \mid f'(p) = 0\}$ we obtain

$$(4) \quad \psi_a(z, w) = \left(\frac{1}{|z|}z, |z|^{\frac{a}{1+a}}w \right).$$

Let us now consider the limit $a \rightarrow \infty$ to enable explicit computations and continue working with the flat pieces only. Afterwards, we will argue using isotopies that our answer remains valid in the original set-up. The points on the flat piece are now

$$\psi_\infty \circ \psi_W(-\varepsilon, q, p) = \left(\frac{-\varepsilon q + p}{\sqrt{\varepsilon^2 + p^2}}, \sqrt{\varepsilon^2 + p^2}q \right).$$

As before, we will flow with the Reeb vector field to page ε . We will use the Hamiltonian vector field

$$X_F = 2g'z\partial_w + 2f'w\partial_z.$$

On the flat piece of S_1 we are interested in, we have

$$X_F = 2z\partial_w.$$

The time- s flow of X_F sends

$$\left(\frac{-\varepsilon q + p}{\sqrt{\varepsilon^2 + p^2}}, \sqrt{\varepsilon^2 + p^2}q \right) \mapsto \left(\frac{-\varepsilon q + p}{\sqrt{\varepsilon^2 + p^2}}, \sqrt{\varepsilon^2 + p^2}q + 2s \frac{-\varepsilon q + p}{\sqrt{\varepsilon^2 + p^2}} \right).$$

We go back with ψ_∞^{-1} , and compute the page number with the map ϑ_r , and find

$$\vartheta_r(\psi_\infty^{-1} \circ Fl_s^{X_F} \circ \psi_\infty \circ \psi_W(-\varepsilon, q, p)) = -\varepsilon + 2s.$$

Putting $s = \varepsilon$, we find the map $\psi_W^{-1} \circ \psi_\infty^{-1} \circ Fl_\varepsilon^{X_F} \circ \psi_\infty \circ \psi_W$ which acts like

$$\begin{aligned} \{-\varepsilon\} \times (q, p) &\mapsto \psi_W^{-1} \circ \psi_\infty^{-1} \left(\frac{-\varepsilon q + p}{\sqrt{\varepsilon^2 + p^2}}, \sqrt{\varepsilon^2 + p^2}q + 2\varepsilon \frac{-\varepsilon q + p}{\sqrt{\varepsilon^2 + p^2}} \right) \\ &= \psi_W^{-1} \circ \psi_\infty^{-1} \left(\frac{-\varepsilon q + p}{\sqrt{\varepsilon^2 + p^2}}, \frac{(p^2 - \varepsilon^2)q + 2\varepsilon p}{\sqrt{\varepsilon^2 + p^2}} \right). \end{aligned}$$

We need to work this out to make the identification with a Dehn twist. Since $\psi_\infty^{-1}(z, w) = (|w|z, \frac{w}{|w|})$ and $\psi_W^{-1}(z, w) = (z \cdot w, w, z - (z \cdot w)w)$ we find

$$\begin{aligned} &\psi_W^{-1} \circ \psi_\infty^{-1} \circ Fl_\varepsilon^{X_F} \circ \psi_\infty \circ \psi_W(-\varepsilon, q, p) \\ &= \left(\varepsilon, \frac{(p^2 - \varepsilon^2)q + 2\varepsilon p}{\varepsilon^2 + p^2}, \frac{(p^2 - \varepsilon^2)p - 2\varepsilon p^2 q}{\varepsilon^2 + p^2} \right). \end{aligned}$$

We will write $(-\varepsilon, q, p) \mapsto (\varepsilon, \tau(q, p))$ for short.

Recognizing the monodromy as a Dehn twist. To interpret the monodromy as a Dehn twist, we only need to recall the rational parametrization of the circle. First we rewrite the previously obtained map τ ,

$$\tau(q, p) = \begin{pmatrix} \frac{p^2 - \varepsilon^2}{\varepsilon^2 + p^2} & \frac{2\varepsilon|p|}{\varepsilon^2 + p^2} \frac{1}{|p|} \\ -\frac{2\varepsilon|p|}{\varepsilon^2 + p^2} |p| & \frac{p^2 - \varepsilon^2}{\varepsilon^2 + p^2} \end{pmatrix} \begin{pmatrix} q \\ p \end{pmatrix}.$$

Now define $g(p)$ such that

$$\cos g(p) = \frac{\varepsilon^2 - p^2}{\varepsilon^2 + p^2}, \quad \sin g(p) = \frac{2\varepsilon|p|}{\varepsilon^2 + p^2},$$

where $g(p)$ increases from 0 near $p = 0$ to π as $|p| \rightarrow \infty$. With this in mind, we see that

$$\tau(q, p) = \begin{pmatrix} -\cos g(|p|) & \sin g(|p|)/|p| \\ -\sin g(|p|)|p| & -\cos g(|p|) \end{pmatrix} \begin{pmatrix} q \\ p \end{pmatrix}.$$

Note that we can recognize this map as a *right-handed* Dehn twist $\sigma_{\tilde{g}(|p|)}$ if we define $\tilde{g}(x) := \pi - g(x)$.

Isotopy to correct the map. Note that we have made two assumptions in the above computation.

- (i) We have ignored the rounding piece, meaning the set

$$\{(z, w) \in F^{-1}(0) \mid f' \neq 0, g' \neq 0\},$$

so the map τ is only the “monodromy” of one of the flat pieces. For later purposes, we will denote the actual “monodromy”, which does take the rounding piece into account, by $\tilde{\tau}$. As explained in Section 3.4.1, the rounding piece has size δ .

- (ii) We have used X_∞ rather than X_a for some $a \in \mathbb{R}$.

We now justify these assumptions.

(i) Note first of all that, outside the rounding piece, the map $\tilde{\tau}$ is either equal to τ or to the identity; we directly see that $\tilde{\tau}(q, p) = \tau(q, p)$ for small $|p|$, and that $\tilde{\tau}(q, p) = (q, p)$ for large $|p|$. We make the small and large more precise in the surgery picture: they correspond to $|z| < 1 + \delta + 2\varepsilon$ and $|w| > 1 - \delta - 2\varepsilon$, as indicated in Figure 9. On the rounding piece we will see that the flow of X_F only gives rise to a small isotopy provided ε and δ are sufficiently small.

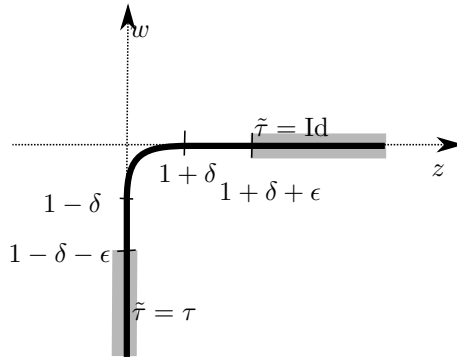

FIGURE 9. Outside the rounding piece the map $\tilde{\tau}$ equals τ or the identity.

We continue to work with ψ_∞ , but now include the rounding piece. The inverse of ψ_∞ can still be explicitly written down,

$$(5) \quad \psi_\infty^{-1} : F^{-1}(0) \rightarrow S_{-1}, \quad (z, w) \mapsto \left(|w|z, \frac{w}{|w|} \right).$$

We have $\psi_\infty^* X_F = (T\psi_\infty)^{-1} X_F \circ \psi_\infty$, so by the inverse function theorem we find

$$T(\psi_\infty^{-1})X_F = \begin{pmatrix} |w| \text{Id} & z \frac{w^t}{|w|} \\ 0 & \frac{1}{|w|} \text{Id} - \frac{ww^t}{|w|^3} \end{pmatrix} \begin{pmatrix} 2f'w \\ 2g'z \end{pmatrix} = \begin{pmatrix} 2f'|w|w + \frac{2g'\langle z, w \rangle}{|w|} z \\ \frac{2g'}{|w|} (z - \langle z, w \rangle \frac{w}{|w|^2}) \end{pmatrix}.$$

Using that the norms $|z|$ and $|w|$ satisfy $|z| \in [1 - \delta, 1 + \delta]$ and $|w| \in [1 - \delta, 1]$ on the rounding piece, we can bound the norm of $\psi_\infty^* X_F$ from above by $8(1 + \delta)^3 / (1 - \delta)$ with repeated use of the triangle inequality. Next, we verify that we still have a good bound on the flow time from page $-\varepsilon$ to page ε on the rounding piece. Indeed, using the triangle inequality and the bounds on $|z|$ and $|w|$, we see that the vector field is “sufficiently transverse” to the pages for small δ ,

$$\begin{aligned} d\vartheta_\tau(\psi_\infty^* X_F) &= (z \cdot dw + w \cdot dz)(\psi_\infty^* X_F) \\ &= \frac{2}{|w|} \left(f'|w|^4 + 2g' \left(|z|^2 + \left(1 - \frac{1}{|w|^2} \right) \langle z, w \rangle^2 \right) \right) \geq 2(1 - 5\delta). \end{aligned}$$

Hence the flow time is bounded from above by

$$\frac{2\varepsilon}{2(1 - 5\delta)} = \frac{\varepsilon}{(1 - 5\delta)}.$$

In particular, on the rounding piece, the flow moves points at most by

$$8\varepsilon \frac{(1 + \delta)^3}{(1 - \delta)(1 - 5\delta)}.$$

We can choose ε and the rounding parameter δ arbitrarily small, so it follows that $\tilde{\tau}$ is symplectically isotopic to a right-handed Dehn twist via an isotopy with compact support.

(ii) From equation (4) (or rather the analogous formula for the inverse in (5)) we see that we can isotope ψ_a to ψ_∞ . Furthermore, this isotopy has compact support, because $\psi_\infty(z, w) = (z, w) = \psi_a(z, w)$ for $|z| \geq 1 + \delta$. Hence the resulting contact manifolds obtained by surgery with the varying parameter a are contactomorphic by Gray stability, and we obtain a compactly supported symplectic isotopy of the “monodromy” map $\tilde{\tau}$.

We conclude that the symplectic monodromy after the surgery is indeed the composition of the symplectic monodromy before surgery with a right-handed Dehn twist. \square

An immediate corollary of the above theorem is the following well-known statement about the relation between fillability and the monodromy of an open book.

Corollary 4.7. *Let $M := \text{OB}(\Sigma, \psi)$ be a contact open book with a Weinstein page Σ and a monodromy that is the product of right-handed Dehn twists. Then M is Stein fillable.*

Proof. The contact manifold $\widetilde{M} := \text{OB}(\Sigma, \text{Id})$ is symplectically fillable with Weinstein filling $\widetilde{W} := \Sigma \times D^2$. By Theorem 4.6, we see that we obtain M from \widetilde{M} by critical surgery along Legendrian spheres. Since this can also be done on cobordism level, we obtain a Weinstein filling for M by attaching critical handles along Legendrian spheres to \widetilde{W} . Eliashberg’s fundamental result then allows deformation into an honest Stein filling, [6]. \square

Remark 4.8. There is also a converse due to Giroux and Pardon [13] which asserts that every Stein-fillable contact manifold admits an open book whose monodromy is the product of right-handed Dehn twists.

If the monodromy is the identity, i.e. the factorization into Dehn twists is empty, then the resulting contact manifold is subcritically fillable. This means that there is a subcritical Stein filling, i.e. a Stein filling of the form $W \times D^2$, where W is some Stein domain. This latter characterization of subcritical Stein manifolds, due to Cieliebak, is proved in [6, Chap. 14.4].

The relation between monodromy and fillability has been used effectively in several papers, most notably in [3].

Remark 4.9. The actual Stein filling depends on the precise factorization of the monodromy into right-handed Dehn twists. Different factorizations of a given monodromy can give rise to distinct Stein fillings for the same contact manifold which is determined by the monodromy itself rather than its factorization into Dehn twists.

The simplest case of this phenomenon occurs for the lens space $L(4, 1)$ with its prequantization contact structure over the 2-sphere. This means that we are considering the contact structure whose defining contact form has the property that all Reeb orbits are periodic with the same period. We may alternatively view $L(4, 1) \cong ST^*\mathbb{R}P^2$ to understand this contact structure.

One can construct a supporting open book whose page is a four times punctured 2-sphere, and whose monodromy is given by the product of four right-handed boundary parallel Dehn twists, one for each boundary component. This way to construct open books for prequantization bundles is part of a general procedure, explained in [5, §5]. The associated Stein filling is diffeomorphic to a disk bundle over S^2 , which is simply-connected.

On the other hand, the lantern relation, [20, Lem. 15.15.1.9], can be used to write the product of these four Dehn twists as the product of three right-handed Dehn twists on the same page. The resulting filling is then the canonical Stein filling $DT^*\mathbb{R}P^2$, which is not simply-connected.

This concept has been worked on by many authors, see [20, Chap. 12.3] for an overview, and recently examples of this phenomenon have been found in higher dimensions, see Oba’s results in [19].

4.10. Stabilization. Let us now consider the contact open book given by $M = \text{OB}(\Sigma^{2n}, \psi)$ and suppose that L is an embedded Lagrangian disk D^n in the page Σ whose boundary ∂L is a Legendrian sphere in $\partial\Sigma$.

As in the previous section we define a new contact open book by

$$\widetilde{M} = \text{OB}(\widetilde{\Sigma}, \widetilde{\psi}),$$

where $\widetilde{\Sigma}$ is obtained from Σ by n -handle attachment along ∂L . The monodromy $\widetilde{\psi}$ restricts to the identity on the attached n -handle and coincides with ψ on Σ . Note that $\widetilde{\Sigma}$ contains a Lagrangian sphere L_S spanned by the Lagrangian disk L and the core of the n -handle.

Remark 4.11. Let us interpret the critical attachment of a handle h to the page Σ of M as subcritical handle attachment to the symplectic cobordism $W := [0, 1] \times M$ as in Proposition 4.2. Denote the result of this handle attachment by \widetilde{W} .

We see that $L_S \subset \widetilde{W}$ intersects the belt sphere of the attached handle transversely in one point, since the part of L_S in the handle has the form $\text{core} \times \{p\} \subset h \times D^2$.

Definition 4.12. Let $M = \text{OB}(\Sigma, \psi)$ be a contact open book with an embedded Lagrangian disk L as above. The contact open book

$$\widetilde{M} := \text{OB}(\widetilde{\Sigma}, \widetilde{\psi} \circ \tau_{L_S})$$

is called the *stabilization* of $\text{OB}(\Sigma, \psi)$ along L .

The following claim is a well-known statement due to Giroux.

Proposition 4.13 (Giroux). *The stabilization of a contact open book $\text{OB}(\Sigma, \psi)$ along a Lagrangian disk L bounding a Legendrian sphere in $\partial\Sigma$ is contactomorphic to the contact manifold $\text{OB}(\Sigma, \psi)$.*

Proof. Let $M^{2n+1} = \text{OB}(\Sigma, \psi)$ be a contact open book and L a Lagrangian disk D^n in a page Σ . To stabilize the open book, we first need to attach an n -handle to Σ along ∂L to obtain a new page $\widetilde{\Sigma}$. The submanifold ∂L of

the binding corresponds to an isotropic sphere S , so on the level of contact manifolds, the first step of stabilizing is realized by performing contact surgery along the isotropic sphere S as in Proposition 4.2. In the language of symplectic cobordisms, we start with a compact piece of the symplectization of M , say $[0, 1] \times M$, and then attach an n -handle to $\{1\} \times M$ along $\{1\} \times S$.

The next step of the stabilization consists of changing the monodromy; we have a Lagrangian sphere in the new page $\tilde{\Sigma}$, which we denote by L . Note that we can assume that L is also a Legendrian sphere in $\text{OB}(\tilde{\Sigma}, \tilde{\psi})$ by Lemma 4.4. The stabilization is given by

$$M_S = \text{OB}(\tilde{\Sigma}, \psi \circ \tau_L).$$

On the level of contact manifolds, this change of monodromy can be realized by performing Legendrian surgery along L , as we can apply Theorem 4.6. In cobordism language, this amounts to attaching an $(n + 1)$ -handle to W along the Legendrian sphere L , as described in Section 3.

By construction of the stabilization, the Legendrian sphere L intersects the belt sphere of the previously attached n -handle in precisely one point, see Remark 4.11. This means that the interpretation of the stabilization procedure in terms of symplectic handle attachment fits exactly the description of symplectic handle cancellation in Section 3.10. Hence we apply the handle cancellation lemma (Lemma 3.14) to see that the stabilization yields a contactomorphic manifold. \square

Acknowledgments. I want to thank Fan Ding, Hansjörg Geiges, Klaus Niederkrüger and Kai Zehmisch for helpful comments and suggestions.

REFERENCES

- [1] B. Acu and R. Avdek, Symplectic mapping class group relations generalizing the chain relation, *Internat. J. Math.* **27** (2016), no. 12, 1650096. MR3575920
- [2] V. I. Arnold, Some remarks on symplectic monodromy of Milnor fibrations, in *The Floer memorial volume*, 99–103, *Progr. Math.*, 133, Birkhäuser, Basel, 1995. MR1362824
- [3] K. Barth, H. Geiges, and K. Zehmisch, The diffeomorphism type of symplectic fillings, arXiv:1607.03310 (2016).
- [4] Y. Chekanov, O. van Koert and F. Schlenk, Minimal atlases of closed contact manifolds, in *New perspectives and challenges in symplectic field theory*, 73–112, CRM Proc. Lecture Notes, 49, Amer. Math. Soc., Providence, 2009. MR2555934
- [5] R. Chiang, F. Ding and O. van Koert, Open books for Boothby–Wang bundles, fibered Dehn twists and the mean Euler characteristic, *J. Symplectic Geom.* **12** (2014), no. 2, 379–426. MR3210581
- [6] K. Cieliebak and Y. Eliashberg, *From Stein to Weinstein and back*, American Mathematical Society Colloquium Publications, 59, American Mathematical Society, Providence, 2012. MR3012475
- [7] F. Ding, H. Geiges and O. van Koert, Diagrams for contact 5-manifolds, *J. Lond. Math. Soc.* (2) **86** (2012), no. 3, 657–682. MR3000825
- [8] M. Dörner, H. Geiges and K. Zehmisch, Open books and the Weinstein conjecture, *Q. J. Math.* **65** (2014), no. 3, 869–885. MR3261972
- [9] H. Geiges, *An introduction to contact topology*, Cambridge Studies in Advanced Mathematics, 109, Cambridge University Press, Cambridge, 2008. MR2397738

- [10] H. Geiges, Contact structures and geometric topology, in *Global differential geometry*, 463–489, Springer Proc. Math., 17, Springer, Heidelberg, 2008. MR3289851
- [11] E. Giroux, Géométrie de contact: de la dimension trois vers les dimensions supérieures, in *Proceedings of the International Congress of Mathematicians, Vol. II (Beijing, 2002)*, 405–414, Higher Ed. Press, Beijing, 2002. MR1957051
- [12] E. Giroux and J.-P. Mohsen, *Contact structures and symplectic fibrations over the circle*, lecture notes, 2003.
- [13] E. Giroux and J. Pardon, Existence of Lefschetz fibrations on Stein and Weinstein domains, *Geom. Topol.* **21** (2017), no. 2, 963–997. MR3626595
- [14] H. Grauert, On Levi’s problem and the imbedding of real-analytic manifolds, *Ann. of Math. (2)* **68** (1958), 460–472. MR0098847
- [15] R. C. Gunning and H. Rossi, *Analytic functions of several complex variables*, Prentice-Hall, Inc., Englewood Cliffs, NJ, 1965. MR0180696
- [16] M. McLean, Symplectic homology of Lefschetz fibrations and Floer homology of the monodromy map, *Selecta Math. (N.S.)* **18** (2012), no. 3, 473–512. MR2960024
- [17] J. Milnor, *Lectures on the h-cobordism theorem*, Notes by L. Siebenmann and J. Sondow, Princeton University Press, Princeton, NJ, 1965. MR0190942
- [18] J. Milnor, *Singular points of complex hypersurfaces*, *Annals of Mathematics Studies*, 61, Princeton University Press, Princeton, NJ, 1968. MR0239612
- [19] T. Oba, Higher-dimensional contact manifolds with infinitely many Stein fillings, arXiv:1608.01427v2 (2016).
- [20] B. Ozbagci and A. I. Stipsicz, *Surgery on contact 3-manifolds and Stein surfaces*, *Bolyai Society Mathematical Studies*, 13, Springer, Berlin, 2004. MR2114165
- [21] P. Seidel, Floer homology and the symplectic isotopy problem, PhD thesis, Oxford, 1997, <http://www-math.mit.edu/~seidel/thesis.pdf>.
- [22] P. Seidel, A long exact sequence for symplectic Floer cohomology, *Topology* **42** (2003), no. 5, 1003–1063. MR1978046
- [23] P. Seidel, *Fukaya categories and Picard–Lefschetz theory*, *Zurich Lectures in Advanced Mathematics*, European Mathematical Society (EMS), Zürich, 2008. MR2441780
- [24] O. van Koert and K. Niederkrüger, Open book decompositions for contact structures on Brieskorn manifolds, *Proc. Amer. Math. Soc.* **133** (2005), no. 12, 3679–3686. MR2163607
- [25] A. Weinstein, Contact surgery and symplectic handlebodies, *Hokkaido Math. J.* **20** (1991), no. 2, 241–251. MR1114405

Received September 6, 2016; accepted June 23, 2017

Otto van Koert

Department of Mathematics and Research Institute of Mathematics,
 Seoul National University,
 Building 27, room 402, San 56-1, Sillim-dong, Gwanak-gu,
 Seoul 08826, Republic of Korea
 E-mail: okoert@snu.ac.kr